

Duo Brazil

Your first Silca Machine



With Duo Brazil Silca introduces an innovative concept of key-cutting machines.

A double carriage makes it possible to cut flat keys for cylinders and vehicles, cruciform, bit and double bit, mail box keys and Papaiz® type keys.

Solid, accurate, made in long lasting materials, the machine guarantees reliable cutting results for all types of keys.

Papaiz® is a registered mark

Silca **Duo Brazil** Key Cutting Machine

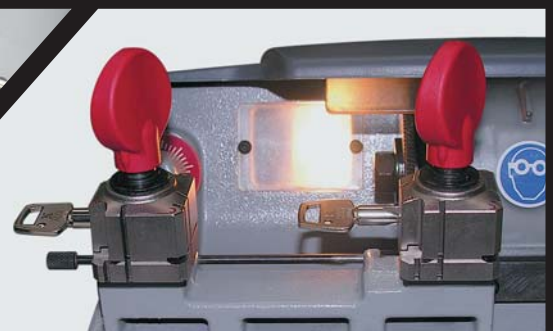

Duo Brazil. Your first Silca Machine.

Mechanical key-cutting machine copying:

- flat cylinder and vehicle keys, cruciform keys and Papaiz® type keys (left-hand carriage);
- bit, double bit and mail box keys (right-hand carriage).

CHARACTERISTICS

- Cutting of various key types
- Reliable and solid
- Durable components
- Compact dimensions
- Cylinder keys carriage: four-sided revolving clamps
- Bit and double bit keys carriage: two/three sided revolving clamps
- Protection of all internal moving parts from swarf intrusion
- Operator safety: mobile cutter safety shield, cut-out switch that triggers automatically if power fails
- On board lighting
- Tool holder
- Swarf tray
- Brush
- Machine built in compliance to the CE Directives

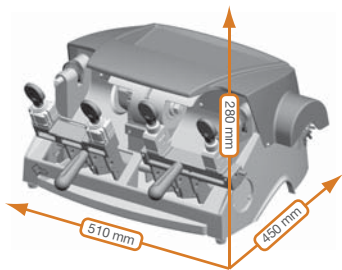
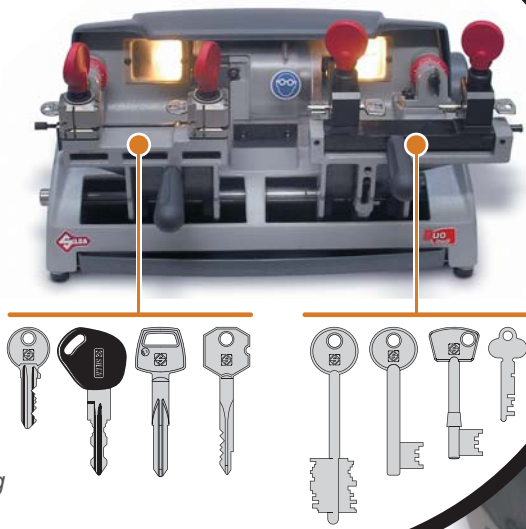

TECHNICAL DATA

Dimensions: 510 x 450 x 280 mm (WxDxH)

Electrical properties: 110V-60Hz

Motor: One-speed single phase

Net weight: 23 Kg

Papaiz® is a registered trade mark

SILCA S.p.A. Via Podgora, 20 (Z.I.) - 31029 Vittorio Veneto (TV) - Italy
Telephone +39 0438 9136 Fax +39 0438 913800

www.silca.biz



SILCA YOUR GLOBAL PARTNER IN LOCKSMITHING