

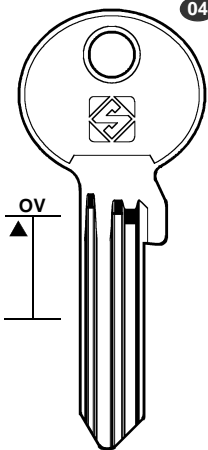
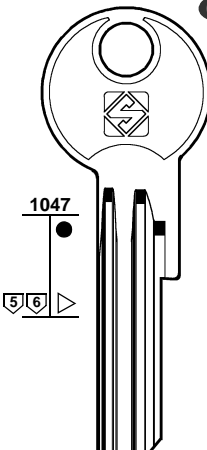
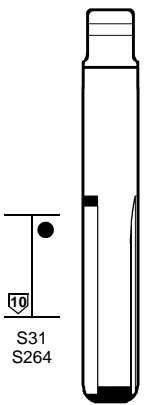
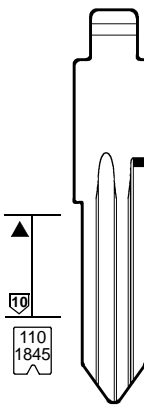
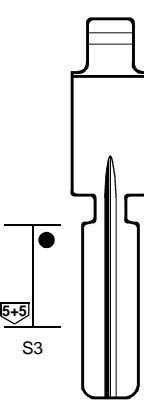
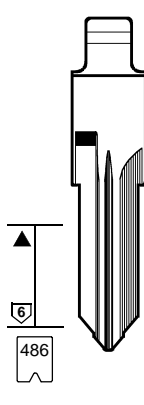
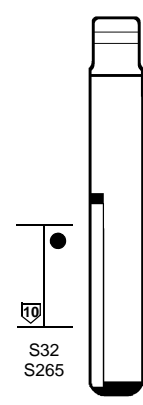
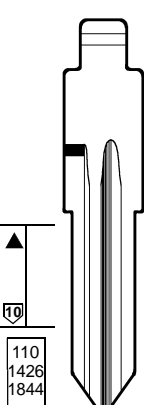

New keys / Chiavi nuove / Neue Schlüssel / Nouvelles clés
Llaves nuevas / Chaves nuevas

FOR: PER:	DAF	FAB	HUF		FOR / PER
	 <p>04</p> <p>OV</p> <p>DF3</p>	 <p>04</p> <p>1047</p> <p>5 6</p> <p>FB13X</p>	 <p>11</p> <p>S31 S264</p> <p>HU43TB</p> <p>H..... WM..... 0001-3000</p> <p>YMO</p>	 <p>10</p> <p>110 1845</p> <p>HU46T</p> <p>S.....1-5200 S.....5298-6300</p> <p>VALEO</p>	DAF (TR) FAB (CS) HUF (D) YMOS VACHETTE (F) VALEO VALEO (F) VACHETTE (1) YMOS (1) YMOS (D) VALEO (1)
FOR: PER:	HUF	VACHETTE	YMOS		
	 <p>11</p> <p>5+5</p> <p>S3</p> <p>HU58T</p> <p>BH..... 010001-241450</p> <p>VALEO</p>	 <p>10</p> <p>6</p> <p>486</p> <p>VAC102-DI</p> <p>..... A/Z 0/9 1-4092 A/Z 0/9 5001-9092 0/9 0/9 1-2-3-4-5</p> <p>VALEO</p>	 <p>11</p> <p>10</p> <p>S32 S265</p> <p>YM27T</p> <p>Y.....1-3000 WY.....1-3000</p> <p>VALEO</p>	 <p>10</p> <p>110 1426 1844</p> <p>YM28T</p> <p>D.....1-5200 S.....1-5200 D.....1-5298-63001002-39974000-5874</p> <p>VALEO</p>	  www.silca.biz 01 COMMERCIAL GROUP GRUPPO COMMERCIALE PREISEGRUPPE GROUPE COMMERCIAL GRUPO COMERCIAL

Car Keys Guide / Guida Chiavi Auto / Führer für Autoschlüssel / Guide Clés pour Voitures Guía Llaves Para Coches / Guia Chaves para Carros

1	2	2a	3	6	71	72	42	43 44a	9b	10b 10c	12	15	A	B	C	D
IGNITION																
CAR MAKE/MODEL	FROM	TO	SILCA REF.	TRANSP. TYPE	ID	COPY	ID	COPY	ID	COPY	STP					
	1995	2010	 Ref.		 FAST COPY PLUS RW4 PLUS	 FAST COPY PLUS RW4 PLUS	 FAST COPY RW4	 FAST COPY RW4	 RW3	 RW3						
ALFA ROMEO																
GIULIETTA	2010		SIP22EHP	PH / CR2	46	Y	46	P-BOX	46				⇐		⇐	
GIULIETTA	2010			PH / CR2	46		46		46				⇐		⇐	
DR MOTORS																
DR1	2009			PH / CR2	46		46		46				⇐	⇐	⇐	
DR5	2007			PH / CR	40		40		40				⇐	⇐	⇐	
NISSAN																
350Z	2003	2009	NI02T	TEX / CR	60		60		60				⇐	⇐	⇐	⇐
370Z	2009		SMART KEY	PH / CR2	46		46		46							
JUKE	2010		NSN14EHP	PH / CR2	46	Y	46	P-BOX	46				⇐			
JUKE	2010			PH / CR2	46		46		46				⇐			
MURANO	2003	2007	NSN14AT13	TEX / CR	XX		XX		XX				⇐	⇐		⇐
MURANO	2003	2007	NSN14EH2	TEX / CR	XX	Y	XX	Y	XX	PC			⇐	⇐		⇐
MURANO	2003	2007	NSN14T13	TEX / CR	XX		XX		XX				⇐	⇐		⇐
NP300	2010		NSN14EHP	PH / CR2	46	Y	46	P-BOX	46				⇐			
PIXO	2009			PH / CR2	46		46		46				⇐			
OPEL-VAUXHALL																
MERIVA	2004	2010	HU100BT12	PH / CR	40		40		40	ID			⇐	⇐		⇐
MERIVA	2004	2010	HU100T12	PH / CR	40		40		40	ID			⇐	⇐		⇐
MERIVA	2010		HU100EHP	PH / CR2	46	Y	46	P-BOX	46							
MERIVA	2010			PH / CR2	46		46		46							
RENAULT-DACIA																
DUSTER	2010		VAC102EHP	PH / CR2	46	Y	46	P-BOX	46				⇐			
DUSTER	2010		VAC102T32	PH / CR2	46		46		46				⇐			

Motorcycle Keys Guide / Guida Chiavi Moto / Führer für Motorräderschlüssel Guide Clés pour Motocyclettes / Guía Llaves Para Motocicletas / Guia Chaves para Motocicletas

1	2	2a	3	6	71	72	42	43 44a	9b	10b 10c	12	15	A	B	C	D
IGNITION																
MOTORCYCLE MAKE/MODEL	FROM	TO	SILCA REF.	TRANSP. TYPE	ID	COPY	ID	COPY	ID	COPY	STP					
	1995	2010	 Ref.		 FAST COPY PLUS RW4 PLUS	 FAST COPY PLUS RW4 PLUS	 FAST COPY RW4	 FAST COPY RW4	 RW3	 RW3						
DUCATI																
MULTISTRADA	2010			TEM / CR	8C		8C		8C							←
HONDA																
HORNET	1998	2002	HON64BP										←	←	←	←
NT650V	1999	2006	HON70EHP	PH / CR2	46	Y	46	P-BOX	46							
NT650V	1999	2006	HON70T14	PH / CR2	46		46		46							
NT700V	2006		HON70EHP	PH / CR2	46	Y	46	P-BOX	46				←		←	
NT700V	2006		HON70T14	PH / CR2	46		46		46				←		←	
YAMAHA																
FZ8	2010		YH35RAT22	TEX / CR	69		69		60			S12	←		←	
FZ8	2010		YH35REH2	TEX / CR	69	Y	69	Y	60	PC			←		←	
XT1200Z Super Ténéré	2010		YH35RAT22	TEX / CR	69		69		60			S12	←		←	
XT600E	1994	2003	YH35RBP										←	←	←	←

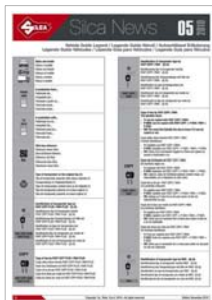

IMPORTANT NOTE:

See also "Vehicle Guide legend"
 Vedi anche "Legenda Guida Veicoli"
 Siehe auch "Autoschlüssel Erläuterung"
 Voir aussi "Légende Guide Véhicules"
 Véase también "Leyenda Guía para Vehículos"
 Veja também "Legenda Guia para Veículos"

FOR:
PER:

Bullet wards

Tagli longitudinali su mappa

Vertikale Nuten auf dem Bart

Entailles longitudinales sur panneton

Cortes longitudinales en el paletón

Cortes longitudinais em palhetão

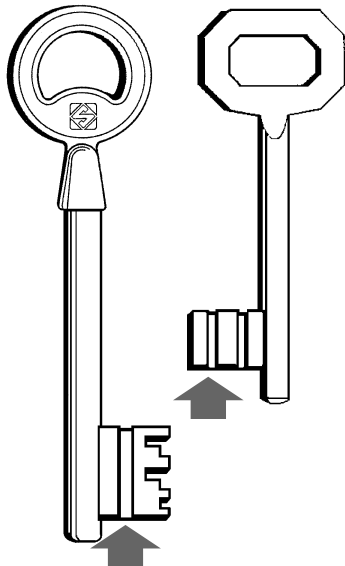

DUO
(all versions)

OPTIONAL

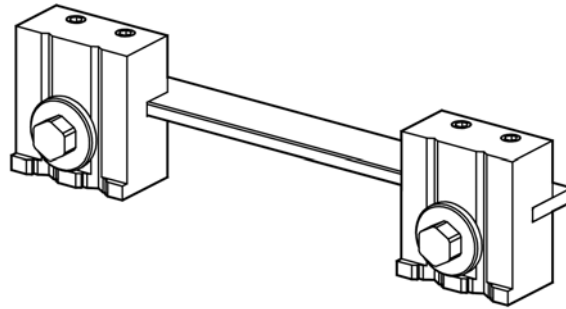

D737681ZB

*Adapters for bullet wards
Adattatori per tagli longitudinali
Adapters für vertikale Nuten
Adaptateurs pour entailles longitudinales
Adaptadores para cortes longitudinales
Adaptadores para cortes longitudinais*

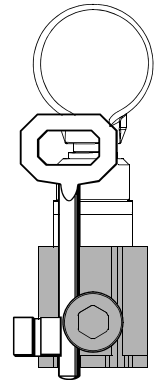

Delivery time DECEMBER 2010
Disponibilità DICEMBRE 2010
Lieferbar DEZEMBER 2010
Disponibilité DECEMBRE 2010
Disponibilidad DICIEMBRE 2010
Disponibilidade DEZEMBRO 2010

KEY CUTTING MACHINES NEWS



UNOCODE 399 PLUS

Code D835724ZB

Codice - Code - Code - Código - Código



 Enter the Evolution of Silca Electronic Key Machines with Unocode 399 Plus.

Unocode 399 Plus:
ease of use, reliability, high precision.

Unocode 399 Plus is the new Silca electronic machine for the cutting of flat cylinder or vehicle keys with single or double sides (by direct or by indirect code). Accurately studied, it adds a high degree of cutting precision to operating speed and ease of use.

Functions/Characteristics:

- Key cutting by direct code (S.A. / PC)
- Key cutting by indirect code (PC)
- "Code Maker" available also in S.A. mode (data card creation or editing)
- Compact updated structure
- Incorporated keypad with graphics display

For further details and information on optional accessories: www.silca.biz

 Découvrez l'Évolution des Machines électroniques à reproduire les clés Silca avec Unocode 399 Plus.

Unocode 399 Plus:
facile à utiliser, fiable, précise.

Unocode 399 Plus est la nouvelle machine électronique Silca pour la reproduction de clés plates pour cylindre ou véhicule à taillage simple ou double (à code direct ou indirect). Étudiée dans les moindres détails, elle allie des performances de rapidité d'exécution et une facilité d'emploi à un très haut niveau de précision dans les résultats.

Fonction/Caractéristiques :

- Duplication par fonction à code direct (S.A. / PC)
- Duplication par fonction à code indirect (PC)
- "Code Maker" est également disponible en mode autonome (création ou modification de la fiche de taillage)
- Structure compacte évolutive
- Clavier de bord avec display graphique

Pour avoir tous les détails et les informations sur les accessoires en Option : www.silca.biz

 Scopri l'Evoluzione delle Duplicatrici Elettroniche Silca con Unocode 399 Plus

Unocode 399 Plus:
facilità di utilizzo, affidabilità, accuratezza

Unocode 399 Plus è la nuova macchina elettronica Silca per la duplicazione di chiavi piatte per cilindri e auto a cifratura singola o doppia (a codice diretto o indiretto). Studiata nei minimi particolari, unisce alle caratteristiche di velocità di esecuzione e di facilità d'uso un elevato grado di precisione nei risultati.

Funzioni/Caratteristiche:

- Duplicazione tramite funzione a codice diretto (S.A. / PC)
- Duplicazione tramite funzione a codice indiretto (PC)
- "Code Maker" disponibile anche in modalità S.A. (creazione o modifica scheda taglio)
- Struttura compatta ed evoluta
- Tastiera a bordo con display grafico

Per maggiori dettagli e informazioni sugli accessori opzionali: www.silca.biz

 Descubra la Evolución de las Duplicadoras Electrónicas Silca con Unocode 399 Plus.

Unocode 399 Plus:
fácil de utilizar, fiable y exacta.

Unocode 399 Plus es la nueva máquina electrónica Silca para duplicar llaves planas para cilindros y coches con cifrado individual o doble (por código directo o indirecto). Estudiada en los detalles más mínimos para añadir a las características de rapidez de ejecución y facilidad de uso un alto grado de precisión en los resultados.

Funciones/Características:

- Duplicación por código directo (S.A. / PC)
- Duplicación por código indirecto (PC)
- "Code Maker" disponible incluso en modalidad stand alone (creación o modificación ficha corte)
- Estructura compacta y evolucionada
- Teclado en la máquina con display gráfico

Para saber mucho más y por informaciones sobre los accesorios opcionales: www.silca.biz

 Entdecken Sie die Evolution der elektronischen Schlüsselkopiermaschinen von Silca mit Unocode 399 Plus.

Unocode 399 Plus: Einfache Bedienung, Zuverlässig, präzise.

Unocode 399 Plus ist eine elektronische Maschine von Silca für die Kopieren von Flachschlüsseln für Zylinder oder Fahrzeuge mit einseitiger oder doppelseitiger Fräsung (mit direktem oder indirektem Code). Die bis ins Detail sorgfältig geplante Maschine gewährleistet schnelles Arbeiten und einfache Bedienung bei höchster Präzision.

Funktionen/Eigenschaften:

- Kopieren mit der Funktion mit direktem Code (S.A. / PC)
- Kopieren mit der Funktion mit indirektem Code (PC)
- "Code Maker" lieferbar auch in der Modalität Stand alone (Generierung oder Änderung der Fräskarte)
- Kompakte und moderne Struktur
- Tastatur an Bord mit graphischem Display

Für mehr Details und Informationen über Optional-Zubehören: www.silca.biz

 Venha descobrir a Evolução das Máquinas Duplicadoras Electrónicas Silca com Unocode 399 Plus.

Unocode 399 Plus:
fácil de utilizar, de confiança, exacta.

Unocode 399 Plus é uma máquina electrónica Silca para a duplicação de chaves planas para cilindro ou veículo de corte simples ou duplo (por código directo ou indirecto). Estudada nos mínimos detalhes, junta às características de velocidade de execução e de facilidade de utilização um nível elevado de precisão nos resultados.

Funções/Características

- Duplicação através da função por código directo (S.A. / PC)
- Duplicação através da função por código indirecto (PC)
- "Code Maker" disponível também na modalidade stand alone (criação ou alteração de ficha de corte)
- Estrutura compacta e evoluída
- Teclado de bordo com visor gráfico

Para detalhes adicionais e para informação sobre os acessórios opcionais: www.silca.biz

Optional accessories: www.silca.biz

SOFTWARE NEWS

SKP Update Version 17.0.x.x



SILCA KEY PROGRAMS

Update 3/2010

Main Contents

NEW

SILCA KEY READER PROGRAM AND OPTIKA NEW FEATURES

SKRP



25 new references

Update with 25 new references.
Aggiornamento con 25 nuove referenze.
Aktualisierung mit 25 neuen Referenzen.
Mise à jour avec 25 nouvelles références.
Actualización con 25 referencias nuevas.
Atualização com 25 novas referências.



To update the Optika Program:



USB Pen Drive

Update with 25 new references.

Please remember to use a USB-PEN memory to update the OPTIKA program.
To download the USB-PEN memory use the "Advanced" function in the OPTIKA "Machine List" on the Key Reader Program (or SKP).

Aggiornamento con 25 nuove referenze.

Ricordarsi di aggiornare il programma di OPTIKA utilizzando una memoria USB-PEN. Per caricare la memoria USB-PEN utilizzare la funzione "Avanzate" della "Anagrafica macchine" OPTIKA del Key Reader Program (o SKP).

Aktualisierung mit 25 neuen Referenzen.

Das Programm von OPTIKA wird mit einem USB-PEN Speicher aktualisiert.
Zum Laden des USB-PEN Speichers die Funktion "Erweiterte" der "Maschinentabelle" OPTIKA des Key Reader Program (oder SKP) verwenden.

Mise à jour avec 25 nouvelles références.

Il faut se rappeler de mettre à jour le programme d'OPTIKA en utilisant une mémoire USB-PEN. Pour charger la mémoire USB-PEN, utiliser la fonction "Avancées" dans le "Fichier machines" OPTIKA de Key Reader Program (ou SKP).

Actualización con 25 referencias nuevas.

Hay que acordarse de actualizar el programa de OPTIKA utilizando una memoria USB-PEN. Para cargar la memoria USB-PEN utilizar la función "Avanzadas" del "Registro máquinas" OPTIKA del Key Reader Program (o SKP).

Atualização com 25 novas referências.

Lembrar de atualizar o programa de OPTIKA utilizando uma memória USB-PEN. Para carregar a memória USB-PEN utilizar a função "Avançadas" de "Dados máquinas" OPTIKA do Key Reader Program (ou SKP).

NEW

SILCA TRANSPONDER PROGRAM NEW FEATURES

STP



63 new vehicle models

Update with 63 new vehicle models.
Aggiornamento con 63 nuovi modelli auto.
Aktualisierung mit 63 neuen Automodellen.
Mise à jour avec 63 nouveaux modèles auto.
Actualización con 63 modelos vehículo nuevos.
Atualização com 63 novos modelos de automóvel.



Silca Transponder Program

Update with 63 new vehicle models.

Addition of 8 new SILCA keys for copies of transponder ID46.

Aggiornamento con 63 nuovi modelli auto.

Aggiunta di 8 nuove chiavi SILCA per la copia del transponder ID46.

Aktualisierung mit 63 neuen Automodellen.

Hinzufügung von 8 neuen SILCA Schlüsseln zum Kopieren des Transponder ID46.

Mise à jour avec 63 nouveaux modèles auto.

Adjonction de 8 nouvelles clés SILCA pour la copie du transpondeur ID46.

Actualización con 63 nuevos modelos vehículo.

Se han añadido 8 llaves nuevas SILCA para la copia del transponder ID46.

Atualização com 63 novos modelos de automóvel.

Foram adicionadas 8 novas chaves SILCA para a cópia do transponder ID46.

SOFTWARE NEWS

SKP Update Version 17.0.x.x



SILCA KEY PROGRAMS

Update 3/2010

Main Contents

NEW

SILCA CODE PROGRAM NEW FEATURES

SCP



Unocode 399 Evo



Unocode 299/399

41 new cutting cards / series

Data update with 41 new cutting cards/series.
 Aggiornamento Dati con 41 nuove serie/schede.
 Datenaktualisierung mit 41 neuen Karten/Serien.
 Mise à jour des données avec 41 nouvelles cartes/séries.
 Mise à jour des données avec 41 nouvelles cartes/séries.
 Atualização de Dados com 41 novas fichas/séries.

 **Data update with 41 new cutting cards/series.**

Update UNOCODE 299/399 and UNOCODE 399 EVO software.

 **Aggiornamento Dati con 41 nuove serie/schede.**

Aggiornare il software di UNOCODE 299/399 e UNOCODE 399 EVO.

 **Datenaktualisierung mit 41 neuen Karten/Serien.**

Aktualisierung der Software von UNOCODE 299/399 und UNOCODE 399 EVO.

 **Mise à jour des données avec 41 nouvelles cartes/séries.**

Mettre à jour le software d' UNOCODE 299/399 et UNOCODE 399 EVO.

 **Actualización Datos con 41 fichas/series nuevas.**

Actualizar el software de UNOCODE 299/399 y UNOCODE 399 EVO.

 **Atualização de Dados com 41 novas fichas/ séries.**

Atualizar o software de UNOCODE 299/399 e UNOCODE 399 EVO.

NEW

SILCA TRIAX E.CODE - QUATTROCODE - VIPER PROGRAM NEW FEATURES



Quattrocode Triax-e.code

25 new series

Data update with 25 new series. / Aggiornamento dati con 25 nuove serie. / Datenaktualisierung mit 25 neuen Serien. / Mise à jour des données avec 25 nouvelles séries. / Actualización datos con 25 series nuevas. / Atualização de dados com 25 novas séries.

New serie

New serie. Please update the software / Nuova serie. Aggiornare il software/ Neue Serie. Aktualisierung der Software / Nouvelle série. Mettre à jour le software / Serie nueva. Actualizar el software / Nova série. Atualizar o software.



Viper

 **TRIAX-E.CODE/QUATTROCODE Data update with 25 new series.**

New items include:
 MAGNUM® Superior, Multilock® MT5+, DOM® IXGAMMA, DOM® IXSATURN, EVVA® 3KS (axis 1 / 2) EVVA® 3KS+ (axis 1), ISEO® R6 Plus, TITAN® T100 X/R...
 (Update TRIAX-E.CODE software)

 **TRIAX-E.CODE/QUATTROCODE Aggiornamento Dati con 25 nuove serie.**

Tra le novità:
 Magnum® MAGNUM® Superior, Multilock® MT5+, DOM® IXGAMMA, DOM® IXSATURN, EVVA® 3KS (axis 1 / 2) EVVA® 3KS+ (axis 1), ISEO® R6 Plus, TITAN® T100 X/R...
 (Aggiornare il software della TRIAX-E.CODE)

 **TRIAX-E.CODE/QUATTROCODE: Datenaktualisierung mit 25 neuen Serien.**

Unter den Neuheiten:
 MAGNUM® Superior, Multilock® MT5+, DOM® IXGAMMA, DOM® IXSATURN, EVVA® 3KS (axis 1 / 2) EVVA® 3KS+ (axis 1), ISEO® R6 Plus, TITAN® T100 X/R...
 (Aktualisierung der Software der TRIAX-E.CODE)

 **TRIAX-E.CODE/QUATTROCODE Mise à jour des données avec 25 nouvelles séries.**

Parmi les nouveautés:
 MAGNUM® Superior, Multilock® MT5+, DOM® IXGAMMA, DOM® IXSATURN, EVVA® 3KS (axis 1 / 2) EVVA® 3KS+ (axis 1), ISEO® R6 Plus, TITAN® T100 X/R...
 (Mettre à jour le software de TRIAX-E.CODE)

 **TRIAX E.-CODE/QUATTROCODE Actualización Datos con 25 series nuevas.**

entre las novedades:
 MAGNUM® Superior, Multilock® MT5+, DOM® IXGAMMA, DOM® IXSATURN, EVVA® 3KS (axis 1 / 2) EVVA® 3KS+ (axis 1), ISEO® R6 Plus, TITAN® T100 X/R...
 (Actualizar el software de la TRIAX-E.CODE)

 **TRIAX E.-CODE/QUATTROCODE Atualização de Dados com 25 novas séries.**

entre as novidades:
 MAGNUM® Superior, Multilock® MT5+, DOM® IXGAMMA, DOM® IXSATURN, EVVA® 3KS (axis 1 / 2) EVVA® 3KS+ (axis 1), ISEO® R6 Plus, TITAN® T100 X/R...
 (Atualizar o software da TRIAX-E.CODE)

SOFTWARE NEWS



SILCA KEY PROGRAMS

New 2011

NEW

SILCA KEY PROGRAMS FUTURE DEVELOPMENTS (JANUARY 2011)

SKP

JAN.
2011



Future developments for SILCA KEY PROGRAMS (from January 2011)

From January 2011 you will also be able to update the SILCA KEY PROGRAMS program on the WEB.

This will generate some changes:

- The electronic support will be DVD only (**no longer CD-ROM**);
- The supported Windows® Operating Systems will be: Windows® 2000, Windows® XP, Windows VISTA™ and Windows® 7;
- Updates for Operating Systems Windows® 95, Windows® ME, Windows® 98 and Windows® NT will no longer be available.

Sviluppi futuri per il SILCA KEY PROGRAMS (Da Gennaio 2011)

Da Gennaio 2011, il programma SILCA KEY PROGRAMS sarà aggiornabile anche tramite il WEB.

Per questo motivo vi saranno alcune novità:

- Il supporto elettronico sarà solo DVD (**non più CD-ROM**)*;
- I Sistemi Operativi Windows® supportati saranno: Windows® 2000, Windows® XP, Windows VISTA™ e Windows® 7;
- Non saranno più disponibili aggiornamenti per sistemi operativi quali Windows® 95, Windows® ME, Windows® 98 e Windows® NT.

* Lo spazio di memorizzazione dei Cdroms non risulta essere più sufficiente a contenere la totalità dei dati e degli applicativi software contenuti negli aggiornamenti Software Silca. Ci vediamo costretti, per tale ragione, a trasferire i nostri aggiornamenti su supporto DVD.

Zukünftige Entwicklungen für das SILCA KEY PROGRAMS (ab Januar 2011)

Ab Januar 2011 ist das Programm SILCA KEY PROGRAMS auch über das WEB aktualisierbar.

Daher gibt es einige Neuheiten:

- Es werden nur mehr DVD verwendet (**nicht mehr CD-ROM**);
- Die Betriebssysteme Windows® sind: Windows® 2000, Windows® XP, Windows VISTA™ und Windows® 7;
- Es gibt keine Aktualisierungen mehr für Betriebssysteme wie Windows® 95, Windows® ME, Windows® 98 und Windows® NT.



SOFTWARE NEWS



SILCA KEY PROGRAMS

New 2011

NEW

SILCA KEY PROGRAMS FUTURE DEVELOPMENTS (JANUARY 2011)

SKP

JAN.
2011



Développements futurs pour SILCA KEY PROGRAMS (A partir de janvier 2011)

Dès Janvier 2011, le logiciel SILCA KEY PROGRAMS pourra être mis à jour sur le Net aussi.

C'est pour cette raison qu'il y aura certaines nouveautés:

- Il n'y aura que le DVD comme support électronique (**plus de CD-ROM**);
- Les systèmes d'exploitation Windows® secondés seront les suivants: Windows® 2000, Windows® XP, Windows VISTA™ et Windows® 7 ;
- Aucune mise à jour pour les systèmes d'exploitation tels que Windows® 95, Windows® ME, Windows® 98 et Windows® NT ne sera disponible.

Desarrollos futuros para el SILCA KEY PROGRAMS (A partir de Enero de 2011)

A partir de Enero de 2011, el programa SILCA KEY PROGRAMS podrá actualizarse incluso por medio de la WEB.

Por este motivo habrá algunas novedades:

- El soporte electrónico será sólo DVD (**ya no CD-ROM**);
- Los Sistemas Operativos Windows® soportados serán: Windows® 2000, Windows® XP, Windows VISTA™ y Windows® 7;
- Ya no estarán disponibles actualizaciones para sistemas operativos como Windows® 95, Windows® ME, Windows® 98 y Windows® NT.

Desenvolvimentos futuros para o SILCA KEY PROGRAMS (De Janeiro de 2011)

A partir de Janeiro de 2011, o programa SILCA KEY PROGRAMS também poderá ser actualizado através da WEB.

Por esta razão, as novidades serão as seguintes:

- O suporte electrónico será apenas DVD (**já não CD-ROM**) ;
- Os Sistemas Operativos Windows® suportados serão: Windows® 2000, Windows® XP, Windows VISTA™ e Windows® 7 ;
- Já não estarão disponíveis actualizações para sistemas operativos como Windows® 95, Windows® ME, Windows® 98 e Windows® NT.

