

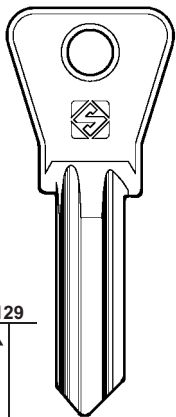

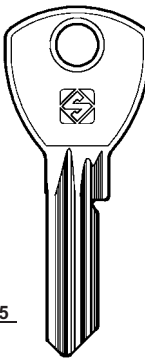







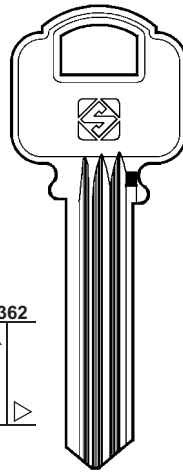
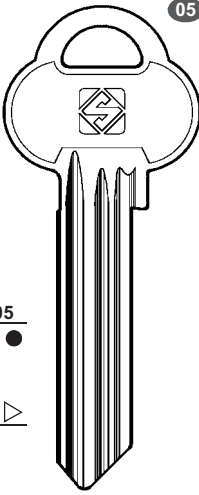
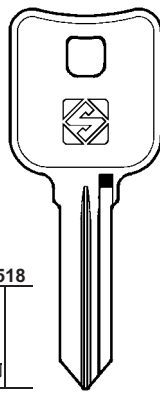

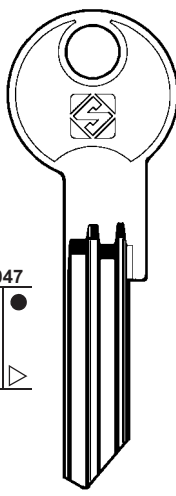
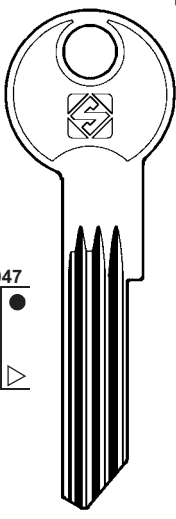

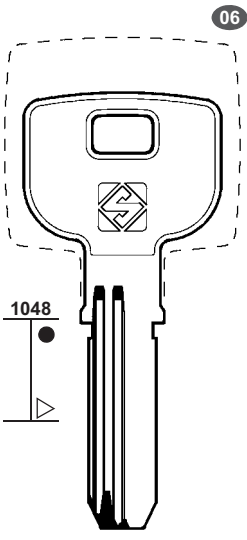
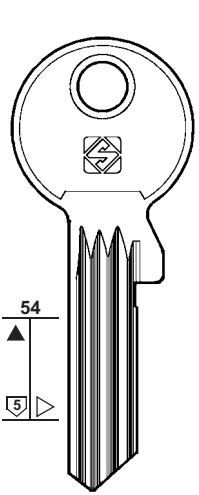
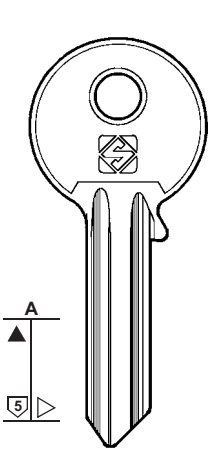
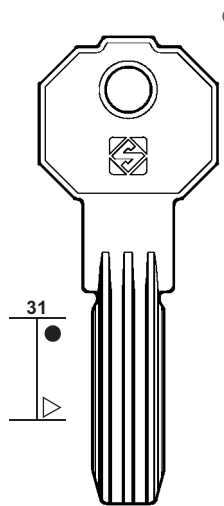

New keys / Chiavi nuove / Neue Schlüssel / Nouvelles clés  
Llaves nuevas / Chaves nuevas

| FOR:<br>PER: | ABC  | ABUS   | ALFA   | ASSA  | FOR / PER   |
|--------------|--|--|--|---|---|
|              |  <p>129</p> <p>AC2</p>  |  <p>1335</p> <p>AB76R</p>  |  <p>1362</p> <p>ALA1R</p>             |  <p>205</p> <p>ASS183<br/>PD</p> <p>ASS183R<br/>PE</p> | ABC (E)<br>ABUS (D)<br>ALFA (S)<br>ASSA (S)<br>BURG (D)<br>FAB (CS)   |
| FOR:<br>PER: | BURG   | FAB  |  |   |   |
|              |  <p>1518</p> <p>BUR38</p>  |  <p>1047</p> <p>FB63X</p> <p>FB62RX<br/>030</p>   |  <p>1047</p> <p>FB64RX<br/>027</p> |   |  <p><a href="http://www.silca.biz">www.silca.biz</a></p> <p>01<br/>           COMMERCIAL GROUP<br/>           GRUPPO COMMERCIALE<br/>           PREISEGRUPPE<br/>           GROUPE COMMERCIAL<br/>           GRUPO COMERCIAL</p> |

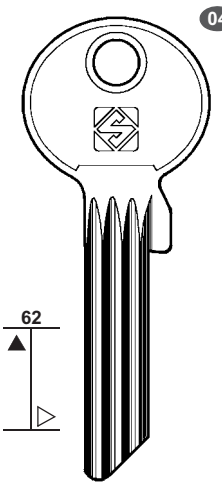
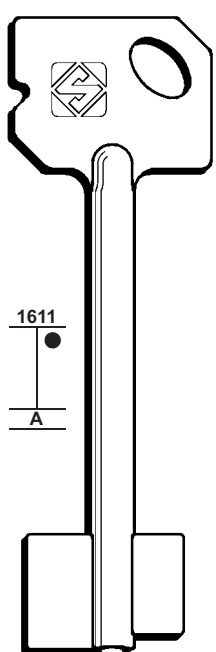
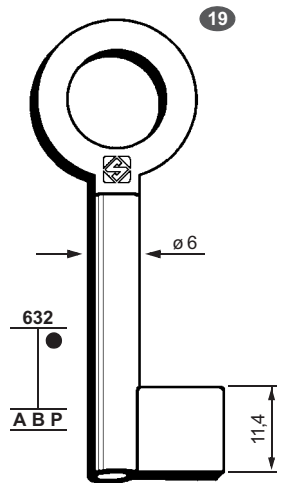
|              |
|--------------|
| FOR / PER    |
| FTH (F)      |
| GEGE (A)     |
| M.S.S. (CHN) |
| PREFER (I)   |
| TITAN (SLO)  |
| HK (CZ)      |
| HOBES (CZ)   |

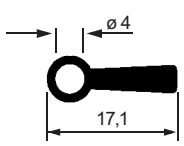
| FOR:<br>PER: | FTH   | GEGE  | M.S.S.   | PREFER   |
|--------------|---|---|--|--|
|              |                  |                  |                  |                 |
|              | <br><b>FH37R</b> | <br><b>GE52X</b> | <br><b>MSF1</b> | <br><b>PF20</b> |
|              |                |   |  |               |

| FOR:<br>PER: | TITAN   | HK   | HOBES  |
|--------------|---|--|--|
|              |                  |    |                   |
|              | <br><b>TN42</b>  | <br><b>5HK1</b>  | <br><b>6HOB10</b> |
|              | <br><b>TN42R</b> |   |  |
|              |   | <p>Published in the "207" catalogue<br/>         Pubblicato nel catalogo "207"<br/>         Im Katalog "207" veröffentlicht<br/>         Publié dans le catalogue "207"<br/>         Publicado en el catálogo "207"<br/>         Publicado no catálogo "207"</p> |  |

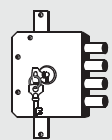

[www.silca.biz](http://www.silca.biz)

01

COMMERCIAL GROUP  
 GRUPPO COMMERCIALE  
 PREISEGRUPPE  
 GROUPE COMMERCIAL  
 GRUPO COMMERCIAL  
 GRUPO COMERCIAL

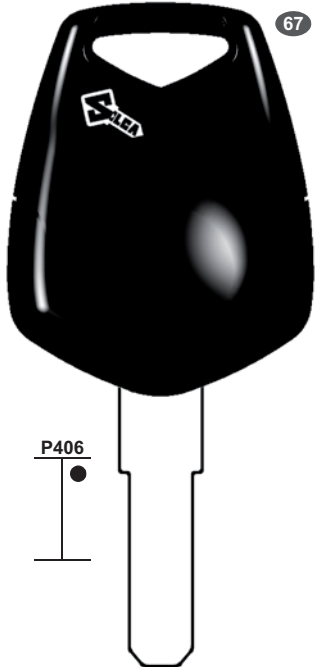
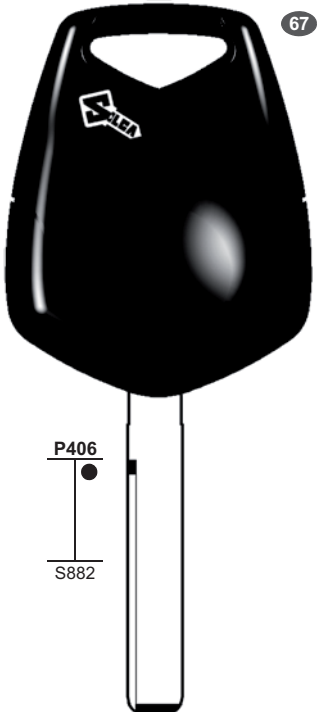
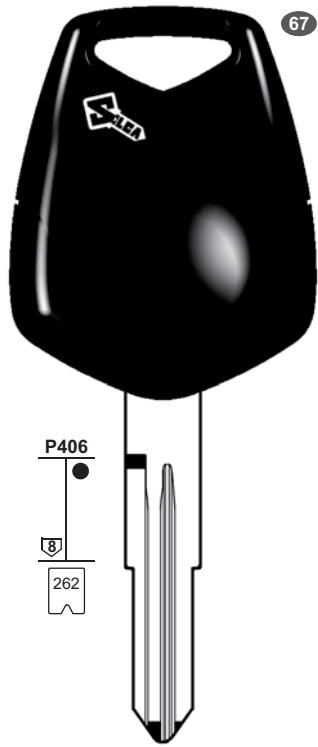
| FOR:<br>PER: | BMW   | GENERAL MOTORS  | HONDA   |
|--------------|---|---|---|
|              |  <p>67</p> <p>P406</p> <p><b>BW9EHP</b></p> |  <p>67</p> <p>P406</p> <p>S882</p> <p><b>GM45EHP</b><br/>60000-62113</p> <p><b>NEW</b> Published in the "The Car Book 3" catalogue<br/>           Pubblicato nel catalogo "The Car Book 3"<br/>           Im Katalog "The Car Book 3" veröffentlicht<br/>           Publié dans le catalogue "The Car Book 3"<br/>           Publicado en el catálogo "The Car Book 3"<br/>           Publicado no catálogo "The Car Book 3"</p> |  <p>67</p> <p>P406</p> <p>262</p> <p><b>HON58REHP</b><br/>... 5001-8442</p> <p><b>NEW</b> Published in the "The Car Book 3" catalogue<br/>           Pubblicato nel catalogo "The Car Book 3"<br/>           Im Katalog "The Car Book 3" veröffentlicht<br/>           Publié dans le catalogue "The Car Book 3"<br/>           Publicado en el catálogo "The Car Book 3"<br/>           Publicado no catálogo "The Car Book 3"</p> |

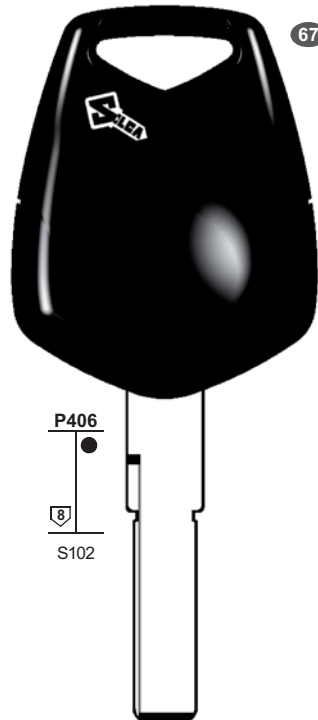
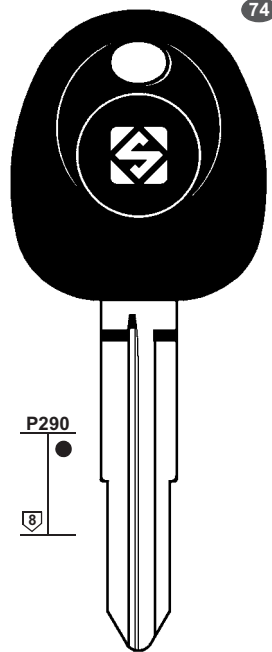
| FOR:<br>PER: | HUF   | HYUNDAI   |
|--------------|---|---|
|              |  <p>67</p> <p>P406</p> <p>S102</p> <p><b>HU66EHP</b><br/>... 1-2000</p> <p><b>NEW</b> Published in the "The Car Book 3" catalogue<br/>           Pubblicato nel catalogo "The Car Book 3"<br/>           Im Katalog "The Car Book 3" veröffentlicht<br/>           Publié dans le catalogue "The Car Book 3"<br/>           Publicado en el catálogo "The Car Book 3"<br/>           Publicado no catálogo "The Car Book 3"</p> |  <p>74</p> <p>P290</p> <p><b>HYN10T14</b></p> |

| FOR / PER                    |
|------------------------------|
| BMW (D)                      |
| GENERAL MOTORS (USA)         |
| GIOBERT (F)<br>TRW SIPEA (5) |
| HONDA (J)                    |
| HUF (D)                      |
| HYUNDAI (ROK)                |



[www.silca.biz](http://www.silca.biz)

01

COMMERCIAL GROUP  
 GRUPPO COMMERCIALE  
 PREISEGRUPPE  
 GROUPE COMMERCIAL  
 GRUPO COMMERCIAL  
 GRUPO COMERCIAL

FOR / PER  
 HYUNDAI (ROK)  
 SIMPLEX (F)  
 TOYOTA (J)

FOR: HYUNDAI  
 PER:

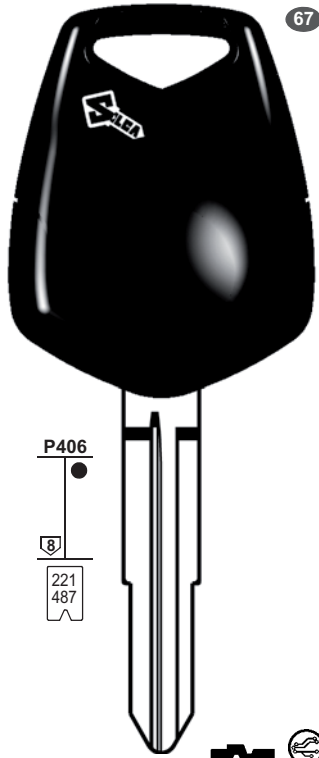

**HYN10EHP**  
 R . . . . 1-1000  
 K . . . . 1-1000



Published in the "The Car Book 3" catalogue  
 Pubblicato nel catalogo "The Car Book 3"  
 Im Katalog "The Car Book 3" veröffentlicht  
 Publié dans le catalogue "The Car Book 3"  
 Publicado en el catálogo "The Car Book 3"  
 Publicado no catálogo "The Car Book 3"

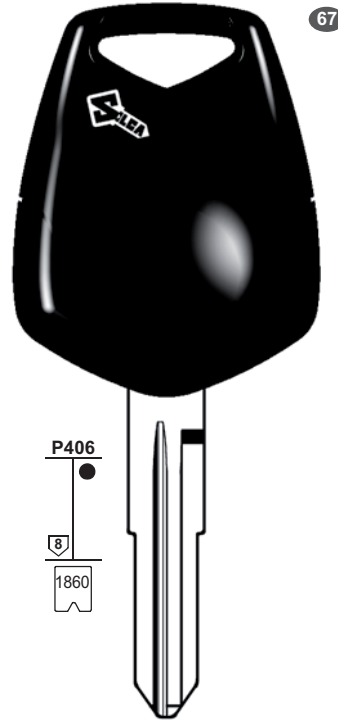

**HYN15EHP**  
 WA . . . . 1001-3040



Published in the "The Car Book 3" catalogue  
 Pubblicato nel catalogo "The Car Book 3"  
 Im Katalog "The Car Book 3" veröffentlicht  
 Publié dans le catalogue "The Car Book 3"  
 Publicado en el catálogo "The Car Book 3"  
 Publicado no catálogo "The Car Book 3"

FOR: SIMPLEX  
 PER:

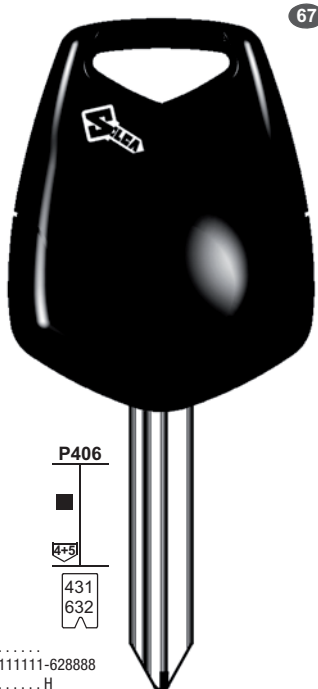

**SX9EHP**

.....  
 0111111-628888  
 ..... H  
 0111111-628888

63/99 . . . . 1-2-4-6-8  
 63/99 . . . . H 1-2-4-6-8



Published in the "The Car Book 3" catalogue  
 Pubblicato nel catalogo "The Car Book 3"  
 Im Katalog "The Car Book 3" veröffentlicht  
 Publié dans le catalogue "The Car Book 3"  
 Publicado en el catálogo "The Car Book 3"  
 Publicado no catálogo "The Car Book 3"

FOR: TOYOTA  
 PER:

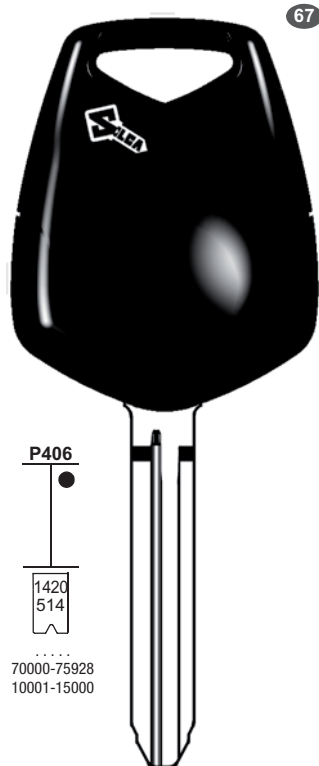

**TOY43REHP**

.....  
 70000-75928  
 10001-15000

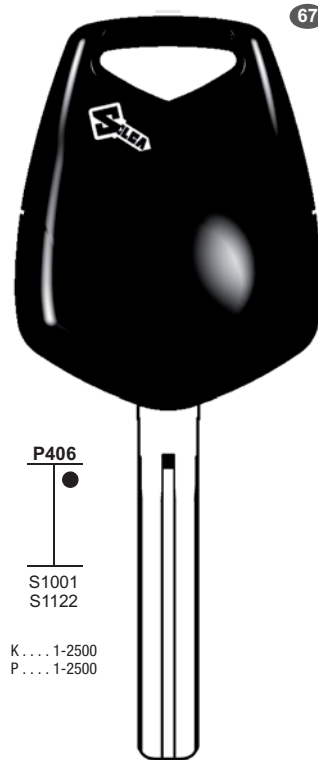

**TOY49EHP**

K . . . . 1-2500  
 P . . . . 1-2500



[www.silca.biz](http://www.silca.biz)

01

COMMERCIAL GROUP  
 GRUPPO COMMERCIALE  
 PREISEGRUPPE  
 GROUPE COMMERCIAL  
 GRUPO COMMERCIAL  
 GRUPO COMERCIAL

FOR: **TRELOCK**  
PER:

Red head  
Testa rossa

10

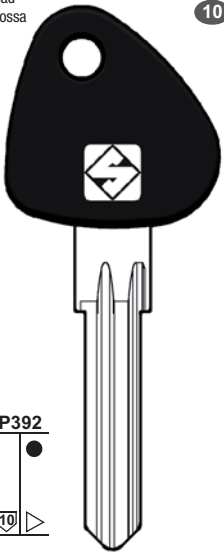

P392



**TRK6P**



**TRW SIPEA**

67

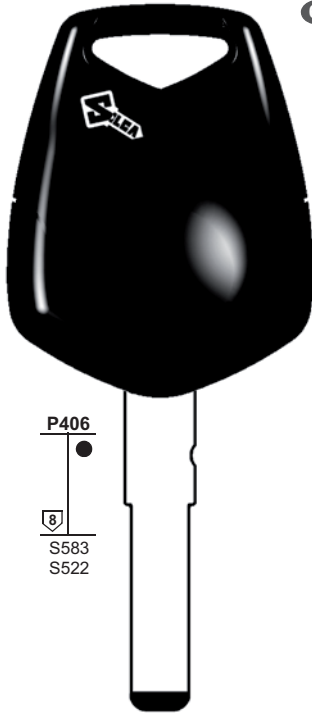

P406



S583  
S522

**SIP22EH2**

DE.....  
1-11210



10

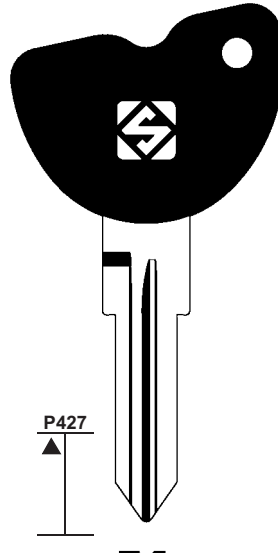

P427



**GT20RDP**



**GIOBERT**



Published in the "The Car Book 3" catalogue  
 Pubblicato nel catalogo "The Car Book 3"  
 Im Katalog "The Car Book 3" veröffentlicht  
 Publié dans le catalogue "The Car Book 3"  
 Publicado en el catálogo "The Car Book 3"  
 Publicado no catálogo "The Car Book 3"

FOR / PER

TRELOCK (D)

TRW SIPEA (I)  
GIOBERT

VACHETTE (F)

ZADI (F)

FOR: **VACHETTE**  
PER:

67

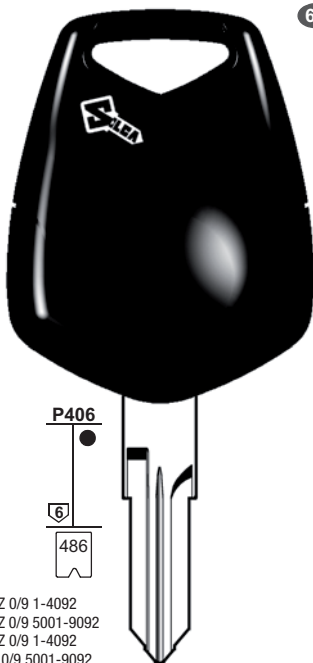

P406



486

.... A/Z 0/9 1-4092  
 .... A/Z 0/9 5001-9092  
 .... A/Z 0/9 1-4092  
 .... A/Z 0/9 5001-9092

**VAC102EHP**



Published in the "The Car Book 3" catalogue  
 Pubblicato nel catalogo "The Car Book 3"  
 Im Katalog "The Car Book 3" veröffentlicht  
 Publié dans le catalogue "The Car Book 3"  
 Publicado en el catálogo "The Car Book 3"  
 Publicado no catálogo "The Car Book 3"

**ZADI**

67

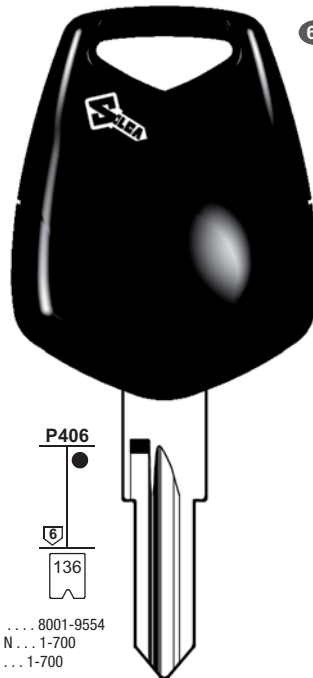

P406



136

.... 8001-9554  
 N... 1-700  
 ... 1-700

**ZD24REHP**



Published in the "The Car Book 3" catalogue  
 Pubblicato nel catalogo "The Car Book 3"  
 Im Katalog "The Car Book 3" veröffentlicht  
 Publié dans le catalogue "The Car Book 3"  
 Publicado en el catálogo "The Car Book 3"  
 Publicado no catálogo "The Car Book 3"











[www.silca.biz](http://www.silca.biz)

01

COMMERCIAL GROUP  
 GRUPPO COMMERCIALE  
 PREISEGRUPPE  
 GROUPE COMMERCIAL  
 GRUPO COMMERCIAL  
 GRUPO COMERCIAL

## Vehicle Guide Legend / Legenda Guida Veicoli / Autoschlüssel Erläuterung Légende Guide Véhicules / Leyenda Guía para Vehículos / Legenda Guia para Veículos

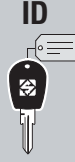
|  |  |
|--|--|
|    | <p><b>Make and model</b><br/>         Marca e modello<br/>         Marke und Modell<br/>         Marque et modèle<br/>         Marca y modelo<br/>         Marca e modelo</p>  |
| <p><b>FROM 1995</b></p>                                     | <p><b>In production from...</b><br/>         Fabbricata dal...<br/>         Hergestellt seit...<br/>         Fabriquée à partir du...<br/>         Fabricada desde...<br/>         Fabricada desde...</p>  |
| <p><b>TO 2010</b></p>                                       | <p><b>In production until...</b><br/>         Fabbricata fino al...<br/>         Hergestellt bis...<br/>         Fabriquée jusqu'au...<br/>         Fabricada hasta...<br/>         Fabricada até...</p>   |
|  <p><b>Ref.</b></p>                                       | <p><b>Silca key reference</b><br/>         Referenza chiave Silca<br/>         Silca-Schlüssel-Referenz<br/>         Référence clé Silca<br/>         Referencia llave Silca<br/>         Referência chave Silca</p>   |
|   | <p><b>Type of transponder on the original key (1)</b><br/>         Tipo di transponder presente nella chiave originale (1)<br/>         Transpondertyp im Originalschlüssel (1)<br/>         Type de transpondeur présent dans la clé originale (1)<br/>         Tipo de transponder presente en la llave original (1)<br/>         Tipo de transponder presente na chave original (1)</p>   |
|  <p><b>FAST COPY PLUS RW4 PLUS</b></p>                    | <p><b>Identification of transponder type by FAST COPY PLUS / RW4 PLUS (2) (4)</b><br/>         Identificazione tipo di transponder tramite FAST COPY PLUS / RW4 PLUS (2) (4)<br/>         Identifizierung des Transpondertyps mit Hilfe der FAST COPY PLUS / RW4 PLUS (2) (4)<br/>         Identification du type de transpondeur par FAST COPY PLUS / RW4 PLUS (2) (4)<br/>         Identificación tipo de transponder por medio de FAST COPY PLUS / RW4 PLUS (2) (4)<br/>         Identificação do tipo de transponder por meio de FAST COPY PLUS / RW4 PLUS (2) (4)</p> |
| <p><b>COPY</b></p>  <p><b>FAST COPY PLUS RW4 PLUS</b></p> | <p><b>Copy of key by FAST COPY PLUS / RW4 PLUS</b><br/>         Copia della chiave tramite FAST COPY PLUS / RW4 PLUS<br/>         Kopie des Schlüssels mit FAST COPY PLUS / RW4 PLUS<br/>         Copie de la clé par FAST COPY PLUS / RW4 PLUS<br/>         Cópia da llave por medio de FAST COPY PLUS / RW4 PLUS<br/>         Cópia da chave por meio de FAST COPY PLUS / RW4 PLUS</p>   |

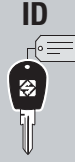
|  |   |
|--|---|
|  <p><b>FAST COPY RW4</b></p>                      | <p><b>Identification of transponder type by FAST COPY / RW4 (2) (4)</b><br/>         Identificazione tipo di transponder tramite FAST COPY / RW4 (2) (4)<br/>         Identifizierung des Transpondertyps mit Hilfe der FAST COPY / RW4 (2) (4)<br/>         Identification du type de transpondeur par FAST COPY / RW4 (2) (4)<br/>         Identificación tipo de transponder por medio de FAST COPY / RW4 (2) (4)<br/>         Identificação do tipo de transponder por meio de FAST COPY / RW4 (2) (4)</p>  |
| <p><b>COPY</b></p>  <p><b>FAST COPY RW4</b></p> | <p><b>Copy of key by FAST COPY / RW4</b><br/> <b>The symbols show:</b></p> <ul style="list-style-type: none"> <li>- <b>Y: can be copied with FAST COPY / RW4;</b></li> <li>- <b>P-BOX: can be copied with FAST COPY + P-BOX / RW4 + P-BOX;</b></li> <li>- <b>RD: You must first identify the key to know if it can be copied or not.</b></li> </ul> <p>Copia della chiave tramite FAST COPY / RW4<br/>         I simboli identificano:<br/>         - <b>Y:</b> Copiabile con FAST COPY / RW4;<br/>         - <b>P-BOX:</b> Copiabile con FAST COPY + P-BOX / RW4 + P-BOX;<br/>         - <b>RD:</b> Indica che è necessario leggere la chiave per sapere se questa è duplicabile o no.</p> <p>Kopie des Schlüssels mit FAST COPY / RW4<br/>         Die Symbole zeigen an:<br/>         - <b>Y:</b> kopierbar mit FAST COPY / RW4;<br/>         - <b>P-BOX:</b> kopierbar mit FAST COPY + P-BOX / RW4 + P-BOX;<br/>         - <b>RD:</b> zeigt an, dass der Schlüssel gelesen werden muss, um festzustellen, ob er kopierbar ist oder nicht.</p> <p>Copie de la clé par FAST COPY / RW4<br/>         Les symboles indiquent:<br/>         - <b>Y:</b> copiable avec FAST COPY / RW4;<br/>         - <b>P-BOX:</b> copiable avec FAST COPY + P-BOX / RW4 + P-BOX;<br/>         - <b>RD:</b> Indique qu'il faut lire la clé pour savoir si elle est reproductible ou pas.</p> <p>Cópia da llave por medio de FAST COPY / RW4<br/>         Los símbolos identifican:<br/>         - <b>Y:</b> copiable con FAST COPY / RW4;<br/>         - <b>P-BOX:</b> copiable con FAST COPY + P-BOX / RW4 + P-BOX;<br/>         - <b>RD:</b> Indica que es necesario leer la llave para saber si ésta es o no es duplicable.</p> <p>Cópia da chave por meio de FAST COPY / RW4<br/>         Os símbolos identificam:<br/>         - <b>Y:</b> Pode ser copiada com FAST COPY / RW4;<br/>         - <b>P-BOX:</b> Pode ser copiada com FAST COPY + P-BOX / RW4 + P-BOX;<br/>         - <b>RD:</b> Indica que é necessário ler a chave para saber se ela pode ou não ser duplicada.</p> |
|  <p><b>RW3</b></p>                              | <p><b>Identification of transponder type by RW3 (3) (4)</b><br/>         Identificazione tipo di transponder tramite RW3 (3) (4)<br/>         Identifizierung des Transpondertyps mit Hilfe der RW3 (3) (4)<br/>         Identification du type de transpondeur par RW3 (3) (4)<br/>         Identificación tipo de transponder por medio de RW3 (3) (4)<br/>         Identificação do tipo de transponder por meio de RW3 (3) (4)</p>  |

## Vehicle Guide Legend / Legenda Guida Veicoli / Autoschlüssel Erläuterung Légende Guide Véhicules / Leyenda Guía para Vehículos / Legenda Guia para Veículos

|         |  |
|---------|--|
| <br>RW3 | <p><b>Copy of key by RW3</b><br/>The symbols show:</p> <ul style="list-style-type: none"> <li>- <b>Y:</b> can be copied with RW3;</li> <li>- <b>ID:</b> The RW3 (latest version in Silca) is able to duplicate the ID (part of the electronic code) of Philips* Crypto transponders.</li> <li>- <b>PC:</b> can be copied with RW3 + Silca Tex Cloning Program</li> </ul> <p>Copia della chiave tramite RW3<br/>I simboli identificano:</p> <ul style="list-style-type: none"> <li>- <b>Y:</b> copiabile con RW3;</li> <li>- <b>ID:</b> RW3 (ultima versione presente in Silca) è in grado di duplicare l'identificatore (parte del codice elettronico) del transponder Crypto Philips* .</li> <li>- <b>PC:</b> copiabile con RW3 + Silca Tex Cloning Program</li> </ul> <p>Kopie des Schlüssels mit RW3<br/>Die Symbole zeigen an:</p> <ul style="list-style-type: none"> <li>- <b>Y:</b> kopierbar mit RW3;</li> <li>- <b>ID:</b> RW3 (letzte Version von Silca) kopiert den Identifikator (Teil des elektronischen Codes) des Transponders Crypto Philips* .</li> <li>- <b>PC:</b> kopierbar mit RW3 + Silca Tex Cloning Program</li> </ul> <p>Copie de la clé par RW3<br/>Les symboles indiquent:</p> <ul style="list-style-type: none"> <li>- <b>Y:</b> copiable avec RW3;</li> <li>- <b>ID:</b> RW3 (dernière version présente chez Silca) est en mesure de reproduire l'identificateur (partie du code électronique) du transpondeur Crypto Philips* .</li> <li>- <b>PC:</b> copiable avec RW3 + Silca Tex Cloning Program</li> </ul> <p>Copia de la llave por medio de RW3<br/>Los símbolos identifican:</p> <ul style="list-style-type: none"> <li>- <b>Y:</b> copiable con RW3;</li> <li>- <b>ID:</b> RW3 (última versión presente en Silca) es capaz de duplicar el identificador (parte del código electrónico) del transponder Crypto Philips* .</li> <li>- <b>PC:</b> copiable con RW3 + Silca Tex Cloning Program</li> </ul> <p>Cópia da chave por meio de RW3<br/>Os símbolos identificam:</p> <ul style="list-style-type: none"> <li>- <b>Y:</b> pode ser copiada com RW3;</li> <li>- <b>ID:</b> RW3 (última versão da Silca) pode duplicar o identificador (parte do código electrónico) do transponder Crypto Philips* .</li> <li>- <b>PC:</b> pode ser copiada com RW3 + Silca Tex Cloning Program</li> </ul> |
|         | <p><b>Indicates the possibility to generate codes for new transponder keys using STP+RW2 or STP+RW3 or STP+RW4 or STP+FAST COPY or STP+RW4 PLUS or STP+FAST COPY PLUS (5)</b></p> <p>Indica la possibilità di generare il codice per nuove chiavi transponder utilizzando STP+RW2 or STP+RW3 or STP+RW4 or STP+FAST COPY or STP+RW4 PLUS or STP+FAST COPY PLUS (5)</p> <p>Zeigt an, daß der Code für neue Transponderschlüssel mit dem STP+RW2 or STP+RW3 or STP+RW4 or STP+FAST COPY or STP+RW4 PLUS or STP+FAST COPY PLUS generiert werden kann (5)</p> <p>Indique la possibilité de générer le code pour de nouvelles clés transponder en utilisant STP+RW2 or STP+RW3 or STP+RW4 or STP+FAST COPY or STP+RW4 PLUS or STP+FAST COPY PLUS (5)</p> <p>Indica la posibilidad de generar el código para nuevas llaves transponder utilizando STP+RW2 or STP+RW3 or STP+RW4 or STP+FAST COPY or STP+RW4 PLUS or STP+FAST COPY PLUS (5)</p> <p>Indica a possibilidade de gerar o código para novas chaves transponder utilizando STP+RW2 or STP+RW3 or STP+RW4 or STP+FAST COPY or STP+RW4 PLUS or STP+FAST COPY PLUS (5)</p>   |

|  |   |
|--|---|
|  | <p><b>Key memorization procedure on the vehicle without using devices (instructions in the STP program)</b></p> <p>Tipo di procedura di memorizzazione della chiave sull'autovettura senza l'utilizzo di dispositivi (istruzioni all'interno del programma STP)</p> <p>Speicherung des Schlüssels im Auto ohne Verwendung der Vorrichtungen (Anleitungen im Programm STP)</p> <p>Procédure de mise en mémoire de la clé sur le véhicule sans utiliser de dispositifs (voir instructions dans le programme STP)</p> <p>Procedimiento de memorización de la llave en el vehículo sin el uso de dispositivos (instrucciones en el interior del programa STP)</p> <p>Tipo de procedimento de memorização da chave no veículo sem utilizar nenhum dispositivo (instruções no programa STP)</p> |
|  | <p><b>Door lock</b><br/>Portiera<br/>Türe<br/>Portière<br/>Puerta<br/>Porta</p>   |
|  | <p><b>Antitheft devices for motor-cycles</b><br/>Antifurto per ciclomotori e motociclette<br/>Diebstahlschutz für Motorfahrad und Motorräder<br/>Anti-vol pour cyclomoteurs/motocyclettes<br/>Anti-hurto para ciclomotores y motocicletas<br/>Anti-roubo para scooters e motocicletas</p>   |
|  | <p><b>Boot / Hatchback</b><br/>Bagagliaio / Portiera posteriore<br/>Kofferraum / Hecktür<br/>Coffre / Portière postérieure<br/>Maletero / Puerta trasera<br/>Bagageira/Porta traseira</p>   |
|  | <p><b>Cycle seat</b><br/>Sella<br/>Sattel<br/>Selle<br/>Silla<br/>Selim</p>   |
|  | <p><b>Petrol cap</b><br/>Tappo benzina<br/>Benzintankverschluss<br/>Bouchon réservoir<br/>Tapa de gasolina<br/>Tampão de gasolina</p>   |
|  | <p><b>Drawer</b><br/>Cassetto<br/>Schublade<br/>Tiroir<br/>Gaveta<br/>Porta-luvas</p>   |

## Vehicle Guide Legend / Legenda Guida Veicoli / Autoschlüssel Erläuterung Légende Guide Véhicules / Leyenda Guía para Vehículos / Legenda Guia para Veículos



All the following information reported in columns 6, 71, 72, 42, 43/44a, 9b, 10b/10c, 12, 15, are relative to car/motorcycle/truck ignition.

Tutti i simboli e le informazioni contenute nelle colonne 6, 71, 72, 42, 43/44a, 9b, 10b/10c, 12, 15, sono relative all'accensione dell'auto/motocicletta/camion.

Alle Symbole u. Informationen in den Spalten 6, 71, 72, 42, 43/44a, 9b, 10b/10c, 12, 15, beziehen sich auf die Zündung des Autos/Motorrads/LKW.

Tous les symboles et les informations reportées dans les colonnes 6, 71, 72, 42, 43/44a, 9b, 10b/10c, 12, 15, sont relatifs à l'allumage de la voiture/motocyclette/camion.

Todos los símbolos y las informaciones en las columnas 6, 71, 72, 42, 43/44a, 9b, 10b/10c, 12, 15, son relativas al encendido del coche/motocicleta/camion.

Todos os símbolos e as informações contidas nas colunas 6, 71, 72, 42, 43/44a, 9b, 10b/10c, 12, 15, dizem respeito à ignição de automóvel/motocicleta/camião.

|     |             |                               |
|-----|-------------|-------------------------------|
| (1) | "PH"        | Transponder Philips*          |
|     | "PH / CR"   | Transponder Philips* Crypto   |
|     | "PH / CR2"  | Transponder Philips* Crypto 2 |
|     | "MEG"       | Transponder Megamos*          |
|     | "MEG / CR"  | Transponder Megamos* Crypto   |
|     | "SOK / CR"  | Sokymat* Crypto               |
|     | "TEXAS"     | Transponder Texas*            |
|     | "TEX / CR"  | Transponder Texas* Crypto     |
|     | "TEX / CR2" | Transponder Texas* Crypto 2   |
|     | "TEMIC"     | Transponder Temic*            |
|     | "MOTOROLA"  | Transponder Motorola*         |
|     | "TEM / CR"  | Transponder Temic*Crypto      |
|     | "SAAB"      | Transponder Saab*             |

|     |   |  |
|-----|---|--|
| (2) | <b>ID TRANSPONDER - FAST COPY PLUS/RW4 PLUS/FAST COPY/RW4</b>   |  |
| 11  | Temic* (Fiat - fixed code) (Fiat - codice fisso) (Fiat - Fixer Code) (Fiat - code fixe) (Fiat - código fijo) (Fiat - código fijo)   |  |
| 12  | Temic* (Mazda-fixed code) (Mazda - codice fisso) (Mazda - Fixer Code) (Mazda - code fixe) (Mazda - código fijo) (Mazda - código fijo)   |  |
| 13  | Megamos* (fixed code) (codice fisso) (Fixer Code) (code fixe) (código fijo) (código fijo)   |  |
| 17  | Silca (fixed code - empty) (codice fisso - vuoto) (silca Fixer Code - leer) (fixe code - vide) (código fijo - vacío) (código fijo - vacío)                                    |  |
| 21  | Silca (fixed code - empty) (codice fisso - vuoto) (silca Fixer Code - leer) (fixe code - vide) (código fijo - vacío) (código fijo - vacío)                                    |  |
| 22  | Silca (fixed code - empty) (codice fisso - vuoto) (silca Fixer Code - leer) (fixe code - vide) (código fijo - vacío) (código fijo - vacío)                                    |  |
| 23  | Silca (fixed code - empty) (codice fisso - vuoto) (silca Fixer Code - leer) (fixe code - vide) (código fijo - vacío) (código fijo - vacío)                                    |  |
| 33  | Philips* (read/ write - fixed code) (read/ write - codice fisso) (read/ write - Fixer Code) (read/ write - code fixe) (read/ write - código fijo) (read/ write - código fijo) |  |
| 40  | Philips* Crypto (Opel*-Vauxhall*)   |  |
| 41  | Philips* Crypto (Nissan*)   |  |
| 42  | Philips* Crypto (VAG*)  |  |
| 44  | Philips* Crypto   |  |
| 45  | Philips* Crypto (Peugeot*)  |  |

|     |  |  |
|-----|--|--|
| (2) | <b>ID TRANSPONDER - FAST COPY PLUS/RW4 PLUS/FAST COPY/RW4</b>  |  |
| 46  | Philips* Crypto (Second generation) (seconda generazione) (Zweite Generation) (Deuxième génération) (segunda generación) (segunda geração)   |  |
| 48  | Megamos* Crypto  |  |
| 53  | Philips* (emulation of Megamos* for Audi*) (emulazione di Megamos* per Audi*) (simuliert Megamos* für Audi*) (émulation de Megamos* pour Audi*) (emulación de Megamos* para Audi*) (emulação de Megamos* para Audi*)             |  |
| 73  | Philips* (multi block - fixed code) (multi blocco - codice fisso) (multi block - Fixer Code) (multi bloc - code fixe) (multi bloque - código fijo) (multi-bloco - código fijo)   |  |
| 93  | Philips* (emulation of Megamos* for Daewoo*) (emulazione di Megamos* per Daewoo*) (simuliert Megamos* für Daewoo*) (émulation de Megamos* pour Daewoo*) (emulación de Megamos* para Daewoo*) (emulação de Megamos* para Daewoo*) |  |
| 4C  | Texas* (fixed code) (codice fisso) (Fixer Code) (code fixe) (código fijo) (código fijo)  |  |
| 4D  | Texas* Crypto  |  |
| 4F  | Philips* Crypto (Fiat* - Alfa Romeo*)  |  |
| 4M  | Philips* Crypto (Mitsubishi*)  |  |
| 4W  | Philips* Crypto (VAG*)   |  |
| 6F  | Texas* Crypto 2  |  |
| 8C  | Temic* Crypto  |  |
| 8D  | Saab* (not duplicable) (non duplicabile) (nicht kopierbar) (non reproductible) (no duplicable) (não pode ser duplicado)  |  |
| 8E  | Sokymat* Crypto  |  |
| A1  | Megamos* Crypto Volkswagen*  |  |
| A2  | Megamos* Crypto Audi*  |  |
| A3  | Megamos* Crypto Seat*  |  |
| A4  | Megamos* Crypto Skoda*   |  |

|     |   |  |
|-----|---|--|
| (3) | <b>ID TRANSPONDER - RW3</b>   |  |
| 11  | Temic* (Fiat - fixed code) (Fiat - codice fisso) (Fiat - Fixer Code) (Fiat - code fixe) (Fiat - código fijo) (Fiat - código fijo)   |  |
| 12  | Temic* (Mazda-fixed code) (Mazda - codice fisso) (Mazda - Fixer Code) (Mazda - code fixe) (Mazda - código fijo) (Mazda - código fijo)   |  |
| 13  | Megamos* (fixed code) (codice fisso) (Fixer Code) (code fixe) (código fijo) (código fijo)   |  |
| 17  | Silca (fixed code - empty) (codice fisso - vuoto) (silca Fixer Code - leer) (fixe code - vide) (código fijo - vacío) (código fijo - vacío)                                    |  |
| 21  | Silca (fixed code - empty) (codice fisso - vuoto) (silca Fixer Code - leer) (fixe code - vide) (código fijo - vacío) (código fijo - vacío)                                    |  |
| 22  | Silca (fixed code - empty) (codice fisso - vuoto) (silca Fixer Code - leer) (fixe code - vide) (código fijo - vacío) (código fijo - vacío)                                    |  |
| 23  | Silca (fixed code - empty) (codice fisso - vuoto) (silca Fixer Code - leer) (fixe code - vide) (código fijo - vacío) (código fijo - vacío)                                    |  |
| 33  | Philips* (read/ write - fixed code) (read/ write - codice fisso) (read/ write - Fixer Code) (read/ write - code fixe) (read/ write - código fijo) (read/ write - código fijo) |  |
| 40  | Philips* Crypto (Opel*-Vauxhall*)   |  |
| 41  | Philips* Crypto (Nissan*)   |  |
| 42  | Philips* Crypto (VAG*)  |  |
| 44  | Philips* Crypto   |  |
| 45  | Philips* Crypto (Peugeot*)  |  |
| 46  | Philips* Crypto (Second generation) (seconda generazione) (Zweite Generation) (Deuxième génération) (segunda generación) (segunda geração)                                    |  |

















## Vehicle Guide Legend / Legenda Guida Veicoli / Autoschlüssel Erläuterung Légende Guide Véhicules / Leyenda Guía para Vehículos / Legenda Guia para Veículos

|            |  |
|------------|--|
| <b>(3)</b> | <p><b>ID TRANSPONDER - RW3</b></p> <p><b>48</b> Megamos* Crypto</p> <p><b>53</b> Philips* (emulation of Megamos* for Audi*) (emulazione di Megamos* per Audi*) (simuliert Megamos* für Audi*) (émulation de Megamos* pour Audi*) (emulación de Megamos* para Audi*) (emulação de Megamos* para Audi*)</p> <p><b>73</b> Philips* (multi block - fixed code) (multi blocco - codice fisso) (multi block - Fixer Code) (multi bloc - code fixe) (multi bloque - código fijo) (multi-bloco - código fixo)</p> <p><b>93</b> Philips* (emulation of Megamos* for Daewoo*) (emulazione di Megamos* per Daewoo*) (simuliert Megamos* für Daewoo*) (émulation de Megamos* pour Daewoo*) (emulación de Megamos* para Daewoo*) (emulação de Megamos* para Daewoo*)</p> <p><b>4C</b> Texas* (fixed code) (codice fisso) (Fixer Code) (code fixe) (código fijo) (código fixo)</p> <p><b>4D</b> Texas* Crypto</p> <p><b>6F</b> Texas* Crypto 2 (only for RW3) (solo per RW3) (nur für RW3) (seulement pour RW3) (sólo por RW3) (só para RW3)</p> <p><b>8C</b> Temic* Crypto</p> <p><b>8D</b> Saab* (not duplicable) (non duplicabile) (nicht kopierbar) (non reproductible) (no duplicable) (não pode ser duplicado)</p>   |
| <b>(4)</b> | <p><b>ID TRANSPONDER TEXAS CRYPTO (4D)</b></p> <p><b>60</b> Texas* Crypto (generic) (generico) (nicht spezifiziert) (générique) (genérico) (genérico)</p> <p><b>61</b> Texas* Crypto Mitsubishi 3</p> <p><b>62</b> Texas* Crypto Mitsubishi 2</p> <p><b>63</b> Texas* Crypto Ford 2</p> <p><b>64</b> Texas* Crypto (Renault &lt;2000, Chrysler, Jeep)</p> <p><b>65</b> Texas* Crypto (Suzuki)</p> <p><b>66</b> Texas* Crypto (Suzuki 2)</p> <p><b>67</b> Texas* Crypto (Toyota/Lexus)</p> <p><b>68</b> Texas* Crypto (Toyota/Lexus 2)</p> <p><b>69</b> Texas* Crypto (Yamaha)</p> <p><b>70</b> Texas* Crypto (Toyota EU)</p> <p><b>XX</b> Texas* Crypto (new or generic) (nuovo o generico) (neu oder nicht spezifiziert) (nouveau ou générique) (nuevo o genérico) (novo ou genérico)</p>   |
| <b>(5)</b> | <p><b>"MEG"</b> Megamos* (type of generation) (tipo di generazione) (Erzeugung Typ) (type de génération) (tipo de generación) (tipo de geração)</p> <p><b>"B - F"</b> Bosch* - Fiat* (type of generation) (tipo di generazione) (Erzeugung Typ) (type de génération) (tipo de generación) (tipo de geração)</p> <p><b>"S - O"</b> Siemens* - Opel* (type of generation) (tipo di generazione) (Erzeugung Typ) (type de génération)+ (tipo de generación) (tipo de geração)</p> <p><b>"M - V"</b> Megamos* - VDO* (type of generation) (tipo di generazione) (Erzeugung Typ) (type de génération) (tipo de generación) (tipo de geração)</p> <p><b>"T - F"</b> Temic* - Fiat* (type of generation) (tipo di generazione) (Erzeugung Typ) (type de génération) (tipo de generación) (tipo de geração)</p> <p><b>"S - V"</b> Siemens* - Volkswagen* (type of generation) (tipo di generazione) (Erzeugung Typ) (type de génération) (tipo de generación) (tipo de geração)</p> <p><b>"G - V"</b> PSA* - Valeo* (type of generation) (tipo di generazione) (Erzeugung Typ) (type de génération) (tipo de generación) (tipo de geração)</p> <p><b>"G - C"</b> PSA* - CPH* (type of generation) (tipo di generazione) (Erzeugung Typ) (type de génération) (tipo de generación) (tipo de geração)</p> <p><b>"N - N"</b> Nissan* (type of generation) (tipo di generazione) (Erzeugung Typ) (type de génération) (tipo de generación) (tipo de geração)</p> |

|            |   |
|------------|---|
| <b>(5)</b> | <p>The keys must then be memorized in the vehicle central immobilizer system.<br/>Le chiavi devono poi essere memorizzate nella centralina immobilizer dell'auto.<br/>Die Schlüssel müssen anschliessend in die Steuerzentrale der Wegfahrsperrung der Autos eingespeichert werden.<br/>Les clés doivent être mises en mémoire dans le central immobiliseur du véhicule.<br/>Las llaves deben memorizarse en la centralita immobilizer del vehículo.<br/>A seguir as chaves devem ser memorizadas na central do sistema de imobilização do veículo.</p> |
|------------|---|

|            |  |
|------------|--|
| <b>(*)</b> | <p><b>IMPORTANT NOTE</b></p> <p>The trade-marks or trade names mentioned in our catalogue are the exclusive property of authorized manufactures of lock and users, they are nominated only for the purposes of information so that any lock for which our keys are made can be rapidly identified.</p> <p>I marchi o le denominazioni citate sono di proprietà esclusiva dei fabbricanti di serrature e degli utilizzatori autorizzati, e sono indicati a titolo di semplice informazione, con lo scopo di riconoscere velocemente a quali serrature le nostre chiavi sono destinate.</p> <p>Die angeführten Markennamen oder Handelsmarken sind ausschließliches Eigentum der Schloßhersteller und zugelassenen Fachhändlern, und sind nur zur Information angeführt, mit dem Zweck, schnell erkennen zu können, zu welchem Schloß unsere Schlüssel passen.</p> <p>Les marques et appellations commerciales citées dans notre catalogue appartiennent exclusivement aux fabricants de serrures et aux utilisateurs autorisés, elles sont indiquées à titre d'information pure et simple pour vous permettre de déterminer rapidement les serrures auxquelles nos clés sont destinées.</p> <p>Las marcas y denominaciones comerciales citadas en nuestro catálogo se declaran de propiedad exclusiva de los fabricantes de cerraduras y los utilizadores autorizados, se citan por simple información, al objeto de hacer comprender sin dificultad a qué cerraduras van destinadas nuestras llaves.</p> <p>As marcas e as denominações citadas são propriedade exclusiva dos fabricantes de fechaduras e dos utilizadores autorizados, e são indicadas apenas a título de informação, a fim de reconhecer rapidamente as fechaduras a que se destinam as nossas chaves.</p> |
|------------|--|

## Car Keys Guide / Guida Chiavi Auto / Führer für Autoschlüssel / Guide Clés pour Voitures Guía Llaves Para Coches / Guia Chaves para Carros

| 1  | 2    | 2a   | 3   | 6   | 71  | 72  | 42  | 43<br>44a   | 9b   | 10b<br>10c   | 12   | 15  | A   | B   | C   | D   |
|--|------|------|---|---|---|---|---|---|--|--|--|---|---|---|---|---|
| <b>IGNITION</b>  |      |      |   |   |   |   |   |   |  |  |  |   |   |   |   |   |
|  |      |      |   |   |   |   |   |   |  |  |  |   |   |   |   |   |
| CAR MAKE/MODEL   | FROM | TO   | SILCA REF.  | TRANSP. TYPE  | ID  | COPY  | ID  | COPY  | ID   | COPY   | STP  |   |   |   |   |   |
|   | 1995 | 2010 | <br>Ref. |  | <br>FAST COPY PLUS<br>RW4 PLUS | <br>FAST COPY PLUS<br>RW4 PLUS | <br>FAST COPY<br>RW4 | <br>FAST COPY<br>RW4 | <br>RW3 | <br>RW3 | <br>STP |  |  |  |  |  |
| <b>AUDI</b>  |      |      |   |   |   |   |   |   |  |  |  |   |   |   |   |   |
| S3   | 2001 | 2004 | HU66AT6   | MEG / CR  | 48  |   | 48  |   | 48   |  |  |   | ←   | ←   | ←   | ←   |
| S4   | 2002 | 2005 | HU66T6  | MEG / CR  | 48  |   | 48  |   | 48   |  |  |   | ←   | ←   | ←   | ←   |
| <b>BMW</b>   |      |      |   |   |   |   |   |   |  |  |  |   |   |   |   |   |
| SERIE 3 (E36)  | 1995 | 2001 |   | PH  | 33  |   | 33  |   | 33   |  |  |   | HU58AP  | ←   |   | ←   |
| SERIE 3 (E46)  | 2002 | 2006 |   | PH  | 73  |   | 73  |   | 73   |  |  |   | HU92RP  | ←   |   | ←   |
| SERIE 3 (E90)  | 2005 |      |   | PH / CR2  | 46  |   | 46  |   | 46   |  |  |   | HU92RP  | ←   |   | ←   |
| SERIE 5 (E39)  | 1996 | 2003 |   | PH  | 33  |   | 33  |   | 33   |  |  |   | HU58AP  | ←   |   | ←   |
| SERIE 5 (E60)  | 2003 | 2010 |   | PH / CR2  | 46  |   | 46  |   | 46   |  |  |   | HU92RP  | ←   |   | ←   |
| SERIE 7 (E38)  | 1994 | 2001 |   | PH  | 33  |   | 33  |   | 33   |  |  |   | HU58AP  | ←   |   | ←   |
| SERIE 7 (E65)  | 2002 | 2008 |   | PH / CR2  | 46  |   | 46  |   | 46   |  |  |   | HU92RP  | ←   |   | ←   |
| SERIE 8 (E31)  | 1995 | 1999 |   | PH  | 33  |   | 33  |   | 33   |  |  |   | HU58AP  | ←   |   | ←   |
| X3   | 2003 |      |   | PH  | 73  |   | 73  |   | 73   |  |  |   | HU92RP  | ←   |   | ←   |
| X5   | 1999 | 2003 |   | PH  | 33  |   | 33  |   | 33   |  |  |   | HU58AP  | ←   |   | ←   |
| X5   | 2004 |      |   | PH / CR2  | 46  |   | 46  |   | 46   |  |  |   | HU92RP  | ←   |   | ←   |
| Z3   | 1995 | 2002 |   | PH  | 33  |   | 33  |   | 33   |  |  |   | HU58AP  | ←   |   | ←   |
| Z4   | 2002 | 2006 |   | PH  | 73  |   | 73  |   | 73   |  |  |   | HU92RP  | ←   |   | ←   |
| Z4   | 2006 |      |   | PH / CR2  | 46  |   | 46  |   | 46   |  |  |   | HU92RP  | ←   |   | ←   |
| Z8   | 2000 | 2003 |   | PH  | 73  |   | 73  |   | 73   |  |  |   | HU58AP  | ←   |   | ←   |
| <b>CHEVROLET S.AMERICA</b>   |      |      |   |   |   |   |   |   |  |  |  |   |   |   |   |   |
| ASTRA  | 2001 | 2007 | HU46T12   | PH / CR   | 40  |   | 40  |   | 40   | ID   |  |   |   |   |   |   |
| ASTRA  | 2007 |      |   | PH / CR2  | 46  |   | 46  |   | 46   |  |  |   | ←   | ←   | ←   | ←   |
| <b>CHEVROLET-DAEWOO</b>  |      |      |   |   |   |   |   |   |  |  |  |   |   |   |   |   |
| LACETTI  | 2004 | 2009 | DWO4REH2  | TEX / CR  | 60  | Y   | 60  | Y   | 60   | PC   |  |   | ←   | ←   | ←   | ←   |
| LACETTI  | 2004 | 2009 |   | TEX / CR  | 60  |   | 60  |   | 60   |  |  |   | ←   | ←   | ←   | ←   |
| <b>FIAT</b>  |      |      |   |   |   |   |   |   |  |  |  |   |   |   |   |   |
| MILLE  | 2005 |      |   | MEG / CR  | 48  |   | 48  |   | 48   |  |  |   | ←   | ←   | ←   | ←   |
| <b>HOLDEN</b>  |      |      |   |   |   |   |   |   |  |  |  |   |   |   |   |   |
| COLORADO   | 2008 |      | TOY43REHP   | PH / CR2  | 46  | Y   | 46  | P-BOX   | 46   |  |  |   | ←   | ←   | ←   |   |
| <b>HONDA</b>   |      |      |   |   |   |   |   |   |  |  |  |   |   |   |   |   |
| CIVIC (Australia)  | 2002 | 2005 | HON66T5   | MEG   | 13  | Y   | 13  | Y   | 13   | Y  | Meg  |   | ←   | ←   |   | ←   |
| CR-V (Australia)   | 2002 | 2006 | HON66T5   | MEG   | 13  | Y   | 13  | Y   | 13   | Y  | Meg  |   | ←   | ←   |   | ←   |
| CR-Z   | 2010 |      | HON66T14  | PH / CR2  | 46  |   | 46  |   | 46   |  |  |   | ←   |   |   |   |
| CR-Z   | 2010 |      | HON66EHP  | PH / CR2  | 46  | Y   | 46  | P-BOX   | 46   |  |  |   | ←   | ←   |   |   |

















Car Keys Guide / Guida Chiavi Auto / Führer für Autoschlüssel / Guide Clés pour Voitures  
Guía Llaves Para Coches / Guia Chaves para Carros

| 1                 | 2    | 2a   | 3         | 6               | 71           | 72                      | 42                      | 43<br>44a     | 9b            | 10b<br>10c | 12   | 15  | A    | B   | C | D |  |  |
|-------------------|------|------|-----------|-----------------|--------------|-------------------------|-------------------------|---------------|---------------|------------|------|-----|------|-----|---|---|--|--|
| CAR MAKE/MODEL    |      |      |           | FROM            | TO           | SILCA REF.              | TRANSP. TYPE            | ID            | COPY          | ID         | COPY | ID  | COPY | STP |   |   |  |  |
| FROM 1995 TO 2010 |      |      |           | SILCA REF. Ref. | TRANSP. TYPE | FAST COPY PLUS RW4 PLUS | FAST COPY PLUS RW4 PLUS | FAST COPY RW4 | FAST COPY RW4 | RW3        | RW3  | STP |      |     |   |   |  |  |
| <b>IGNITION</b>   |      |      |           |                 |              |                         |                         |               |               |            |      |     |      |     |   |   |  |  |
|                   |      |      |           |                 |              |                         |                         |               |               |            |      |     |      |     |   |   |  |  |
| <b>HUMMER</b>     |      |      |           |                 |              |                         |                         |               |               |            |      |     |      |     |   |   |  |  |
| H2 SUT            | 2008 |      | B111-PT   | PH / CR2        | 46           |                         | 46                      |               | 46            |            |      |     | ⇐    | ⇐   |   |   |  |  |
| <b>HYUNDAI</b>    |      |      |           |                 |              |                         |                         |               |               |            |      |     |      |     |   |   |  |  |
| ATOS PRIME        | 2002 | 2008 | HYN10T14  | PH / CR2        | 46           |                         | 46                      |               | 46            |            |      |     | ⇐    | ⇐   |   |   |  |  |
| I20               | 2008 |      | TOY49EHP  | PH / CR2        | 46           | Y                       | 46                      | P-BOX         | 46            |            |      |     | ⇐    | ⇐   | ⇐ | ⇐ |  |  |
| I30               | 2007 |      | TOY49EHP  | PH / CR2        | 46           | Y                       | 46                      | P-BOX         | 46            |            |      |     | ⇐    | ⇐   |   | ⇐ |  |  |
| I40               | 2010 |      | TOY49EHP  | PH / CR2        | 46           | Y                       | 46                      | P-BOX         | 46            |            |      |     | ⇐    | ⇐   | ⇐ | ⇐ |  |  |
| I45               | 2009 |      | TOY49EHP  | PH / CR2        | 46           | Y                       | 46                      | P-BOX         | 46            |            |      |     | ⇐    | ⇐   | ⇐ | ⇐ |  |  |
| <b>KIA</b>        |      |      |           |                 |              |                         |                         |               |               |            |      |     |      |     |   |   |  |  |
| JOICE             | 2000 | 2003 | KIA3REH2  | TEX / CR        | 60           | Y                       | 60                      | Y             | 60            | PC         |      |     | ⇐    | ⇐   | ⇐ | ⇐ |  |  |
| JOICE             | 2000 | 2003 | KIA3RT16  | TEX / CR        | 60           |                         | 60                      |               | 60            |            |      |     | ⇐    | ⇐   | ⇐ | ⇐ |  |  |
| <b>LANCIA</b>     |      |      |           |                 |              |                         |                         |               |               |            |      |     |      |     |   |   |  |  |
| MUSA              | 2004 | 2009 |           | MEG / CR        | 48           |                         | 48                      |               | 48            |            |      |     | ⇐    | ⇐   | ⇐ | ⇐ |  |  |
| MUSA              | 2009 |      | SIP22EHP  | PH / CR2        | 46           | Y                       | 46                      | P-BOX         | 46            |            |      |     | ⇐    | ⇐   | ⇐ | ⇐ |  |  |
| <b>LINCOLN</b>    |      |      |           |                 |              |                         |                         |               |               |            |      |     |      |     |   |   |  |  |
| MKS               | 2009 |      |           | TEX / CR        | 63           |                         | 63                      |               | 63            |            |      |     |      |     |   |   |  |  |
| MKT               | 2010 |      |           | TEX / CR        | 63           |                         | 63                      |               | 63            |            |      |     |      |     |   |   |  |  |
| <b>MAZDA</b>      |      |      |           |                 |              |                         |                         |               |               |            |      |     |      |     |   |   |  |  |
| PREMACY           | 2000 | 2004 |           | TEM / CR        | 8C           |                         | 8C                      |               | 8C            |            |      |     | ⇐    | ⇐   | ⇐ | ⇐ |  |  |
| <b>MITSUBISHI</b> |      |      |           |                 |              |                         |                         |               |               |            |      |     |      |     |   |   |  |  |
| DIAMANTE          | 2002 | 2006 | MIT8EH2   | TEX / CR        | 61           | Y                       | 61                      | Y             | 61            | PC         |      |     | ⇐    | ⇐   | ⇐ | ⇐ |  |  |
| DIAMANTE          | 2002 | 2006 | MIT8T19   | TEX / CR        | 61           |                         | 61                      |               | 61            |            |      |     | ⇐    | ⇐   | ⇐ | ⇐ |  |  |
| ENDEAVOR          | 2003 | 2005 | MIT8T19   | TEX / CR        | 61           |                         | 61                      |               | 61            |            |      |     | ⇐    | ⇐   | ⇐ | ⇐ |  |  |
| GRANDIS           | 2003 |      |           | PH / CR2        | 46           |                         | 46                      |               | 46            |            |      |     | ⇐    | ⇐   |   | ⇐ |  |  |
| GRANDIS           | 2003 |      | MIT11REHP | PH / CR2        | 46           | Y                       | 46                      | P-BOX         | 46            |            |      |     | ⇐    | ⇐   |   | ⇐ |  |  |
| LANCER EVO        | 2003 | 2006 | MIT11RT19 | TEX / CR        | 61           |                         | 61                      |               | 61            |            |      |     | ⇐    | ⇐   | ⇐ |   |  |  |
| MONTERO IO        | 2000 | 2006 | MIT11REH2 | TEX / CR        | 61           | Y                       | 61                      | Y             | 61            | PC         |      |     | ⇐    | ⇐   |   | ⇐ |  |  |
| MONTERO IO        | 2000 | 2006 | MIT11RT19 | TEX / CR        | 61           |                         | 61                      |               | 61            |            |      |     | ⇐    | ⇐   |   | ⇐ |  |  |
| <b>NISSAN</b>     |      |      |           |                 |              |                         |                         |               |               |            |      |     |      |     |   |   |  |  |
| ALMERA            | 2003 | 2006 | NSN14EH2  | TEX / CR        | XX           | Y                       | XX                      | Y             | XX            | PC         |      |     | ⇐    | ⇐   |   | ⇐ |  |  |
| ALMERA TINO       | 2004 | 2006 |           | PH / CR2        | 46           |                         | 46                      |               | 46            |            |      |     | ⇐    | ⇐   |   | ⇐ |  |  |
| MICRA MARCH [J]   | 2000 | 2003 | NSN11AT13 | TEX / CR        | 60           |                         | 60                      |               | 60            |            |      |     | ⇐    | ⇐   |   | ⇐ |  |  |
| MICRA MARCH [J]   | 2000 | 2003 | NSN11T13  | TEX / CR        | 60           |                         | 60                      |               | 60            |            |      |     | ⇐    | ⇐   |   | ⇐ |  |  |
| NAVARA            | 2003 | 2005 | NSN14AT13 | TEX / CR        | XX           |                         | XX                      |               | XX            |            |      |     | ⇐    | ⇐   |   | ⇐ |  |  |

















## Car Keys Guide / Guida Chiavi Auto / Führer für Autoschlüssel / Guide Clés pour Voitures Guía Llaves Para Coches / Guia Chaves para Carros

| 1                           | 2    | 2a   | 3          | 6            | 71                             | 72                             | 42                   | 43<br>44a            | 9b      | 10b<br>10c | 12  | 15 | A | B | C | D |
|-----------------------------|------|------|------------|--------------|--------------------------------|--------------------------------|----------------------|----------------------|---------|------------|-----|----|---|---|---|---|
|                             |      |      |            |              |                                |                                |                      |                      |         |            |     |    |   |   |   |   |
| CAR MAKE/MODEL              | FROM | TO   | SILCA REF. | TRANSP. TYPE | ID                             | COPY                           | ID                   | COPY                 | ID      | COPY       | STP |    |   |   |   |   |
|                             | 1995 | 2010 | <br>Ref.   |              | <br>FAST COPY PLUS<br>RW4 PLUS | <br>FAST COPY PLUS<br>RW4 PLUS | <br>FAST COPY<br>RW4 | <br>FAST COPY<br>RW4 | <br>RW3 | <br>RW3    |     |    |   |   |   |   |
| <b>NISSAN</b>               |      |      |            |              |                                |                                |                      |                      |         |            |     |    |   |   |   |   |
| NAVARA                      | 2003 | 2005 | NSN14T13   | TEX / CR     | XX                             |                                | XX                   |                      | XX      |            |     |    | ↔ | ↔ |   | ↔ |
| NAVARA                      | 2003 | 2005 | NSN14EH2   | TEX / CR     | 60                             | Y                              | 60                   | Y                    | 60      | PC         |     |    | ↔ | ↔ | ↔ | ↔ |
| NAVARA                      | 2003 | 2005 | NSN14EH2   | TEX / CR     | XX                             | Y                              | XX                   | Y                    | XX      | PC         |     |    | ↔ | ↔ | ↔ | ↔ |
| NAVARA                      | 2003 | 2005 | NSN14AT13  | TEX / CR     | 60                             |                                | 60                   |                      | 60      |            |     |    | ↔ | ↔ | ↔ | ↔ |
| NAVARA                      | 2003 | 2005 | NSN14T13   | TEX / CR     | 60                             |                                | 60                   |                      | 60      |            |     |    | ↔ | ↔ | ↔ | ↔ |
| NAVARA                      | 2005 |      |            | PH / CR2     | 46                             |                                | 46                   |                      | 46      |            |     |    | ↔ | ↔ | ↔ |   |
| NAVARA                      | 2005 |      | NSN14EHP   | PH / CR2     | 46                             | Y                              | 46                   | P-BOX                | 46      |            |     |    | ↔ | ↔ | ↔ | ↔ |
| SENTRA                      | 2000 | 2006 | NI02T      | TEX / CR     | 60                             |                                | 60                   |                      | 60      |            |     |    |   |   |   |   |
| <b>PLYMOUTH</b>             |      |      |            |              |                                |                                |                      |                      |         |            |     |    |   |   |   |   |
| NEON                        | 2000 | 2005 | CY24EH2    | TEX / CR     | 64                             | Y                              | 64                   | Y                    | 64      | PC         |     |    | ↔ | ↔ | ↔ | ↔ |
| NEON                        | 2000 | 2005 | Y160-PT    | TEX / CR     | 64                             |                                | 64                   |                      | 64      |            |     | F  | ↔ | ↔ | ↔ | ↔ |
| PROWLER                     | 2000 | 2002 | CY24EH2    | TEX / CR     | 64                             | Y                              | 64                   | Y                    | 64      | PC         |     |    | ↔ | ↔ | ↔ | ↔ |
| PROWLER                     | 2000 | 2002 | Y160-PT    | TEX / CR     | 64                             |                                | 64                   |                      | 64      |            |     | F  | ↔ | ↔ | ↔ | ↔ |
| <b>ROVER</b>                |      |      |            |              |                                |                                |                      |                      |         |            |     |    |   |   |   |   |
| 45                          | 2000 | 2005 |            | PH           | 73                             |                                | 73                   |                      | 73      |            |     |    |   |   |   |   |
| <b>SAAB</b>                 |      |      |            |              |                                |                                |                      |                      |         |            |     |    |   |   |   |   |
| 900                         | 1997 | 1998 | YM30P      |              |                                |                                |                      |                      |         |            |     |    | ↔ | ↔ |   |   |
| 9000                        | 1997 | 1998 | YM30P      |              |                                |                                |                      |                      |         |            |     |    | ↔ | ↔ |   |   |
| 9-3                         | 1998 | 2003 |            | SAAB         | 8D                             |                                | 8D                   |                      | 8D      |            |     |    |   |   |   |   |
| 9-3                         | 2003 |      |            | PH / CR2     | 46                             |                                | 46                   |                      | 46      |            |     |    |   |   |   |   |
| 9-5                         | 1998 | 2002 |            | SAAB         | 8D                             |                                | 8D                   |                      | 8D      |            |     |    |   |   |   |   |
| 9-5                         | 2003 |      |            | PH / CR2     | 46                             |                                | 46                   |                      | 46      |            |     |    |   |   |   |   |
| <b>SEAT</b>                 |      |      |            |              |                                |                                |                      |                      |         |            |     |    |   |   |   |   |
| CORDOBA                     | 2002 | 2009 | HU66T6     | MEG / CR     | 48                             |                                | 48                   |                      | 48      |            |     |    | ↔ | ↔ | ↔ | ↔ |
| IBIZA                       | 2002 | 2009 | HU66T6     | MEG / CR     | 48                             |                                | 48                   |                      | 48      |            |     |    | ↔ | ↔ | ↔ | ↔ |
| IBIZA                       | 2008 |      |            | MEG / CR     | A3                             |                                | A3                   |                      | 48      |            |     |    | ↔ | ↔ | ↔ |   |
| <b>SKODA</b>                |      |      |            |              |                                |                                |                      |                      |         |            |     |    |   |   |   |   |
| FABIA                       | 2000 | 2006 | HU66AT6    | MEG / CR     | 48                             |                                | 48                   |                      | 48      |            |     |    | ↔ | ↔ |   |   |
| <b>VOLKSWAGEN S.AMERICA</b> |      |      |            |              |                                |                                |                      |                      |         |            |     |    |   |   |   |   |
| GOL                         | 2009 |      |            | MEG / CR     | A1                             |                                | A1                   |                      | 48      |            |     |    | ↔ | ↔ | ↔ |   |
| VOYAGE                      | 2009 |      |            | MEG / CR     | A1                             |                                | A1                   |                      | 48      |            |     |    | ↔ | ↔ | ↔ | ↔ |

## Motorcycle Keys Guide / Guida Chiavi Moto / Führer für Motorräderschlüssel Guide Clés pour Motocyclettes / Guía Llaves Para Motocicletas / Guia Chaves para Motocicletas

| 1  | 2           | 2a        | 3   | 6   | 71  | 72  | 42  | 43<br>44a   | 9b   | 10b<br>10c   | 12  | 15  | A   | B   | C   | D   |
|--|-------------|-----------|---|---|---|---|---|---|--|--|---|---|---|---|---|---|
| <b>IGNITION</b>  |             |           |   |   |   |   |   |   |  |  |   |   |   |   |   |   |
|  |             |           |   |   |   |   |   |   |  |  |   |   |   |   |   |   |
| <b>MOTORCYCLE MAKE/MODEL</b>   | <b>FROM</b> | <b>TO</b> | <b>SILCA REF.</b>   | <b>TRANSP. TYPE</b>   | <b>ID</b>   | <b>COPY</b>   | <b>ID</b>   | <b>COPY</b>   | <b>ID</b>  | <b>COPY</b>  | <b>STP</b>  |   |   |   |   |   |
|    | 1995        | 2010      | <br>Ref. |  | <br>FAST COPY PLUS<br>RW4 PLUS | <br>FAST COPY PLUS<br>RW4 PLUS | <br>FAST COPY<br>RW4 | <br>FAST COPY<br>RW4 | <br>RW3 | <br>RW3 |  |  |  |  |  |  |
| <b>BMW</b>   |             |           |   |   |   |   |   |   |  |  |   |   |   |   |   |   |
| F650   | 1993        | 2000      | ZD28RFP   |   |   |   |   |   |  |  |   |   | ←   | ←   |   |   |
| F650   | 2008        |           | BW9EHP  | PH / CR2  | 46  | Y   | 46  | P-BOX   | 46   |  |   |   |   |   | ←   |   |
| F800   | 2006        |           | BW9EHP  | PH / CR2  | 46  | Y   | 46  | P-BOX   | 46   |  |   |   |   |   | ←   |   |
| K1100LS  | 1994        | 1999      | BW7BP   |   |   |   |   |   |  |  |   |   | ←   | ←   |   | ←   |
| K1100LT  | 1994        | 1999      | BW7BP   |   |   |   |   |   |  |  |   |   | ←   | ←   |   | ←   |
| K1200  | 2005        |           | BW9EHP  | PH / CR2  | 46  | Y   | 46  | P-BOX   | 46   |  |   |   |   |   | ←   |   |
| R1100GS  | 1994        | 1999      | BW7BP   |   |   |   |   |   |  |  |   |   | ←   | ←   |   | ←   |
| R1100R   | 1994        | 1999      | BW7BP   |   |   |   |   |   |  |  |   |   | ←   | ←   |   | ←   |
| R1100RT  | 1994        | 1999      | BW7BP   |   |   |   |   |   |  |  |   |   | ←   | ←   |   | ←   |
| R1200  | 2005        |           | BW9EHP  | PH / CR2  | 46  | Y   | 46  | P-BOX   | 46   |  |   |   |   |   | ←   |   |

## Truck keys guide / Guida chiavi camion / Führer für LKW Schlüssel Guide clés pour camions / Guía llaves para camiones / Guia chaves para camiões

| 1  | 2           | 2a        | 3   | 6   | 71  | 72  | 42  | 43<br>44a   | 9b   | 10b<br>10c   | 12  | 15  | A   | B   | C   | D   |
|--|-------------|-----------|---|---|---|---|---|---|--|--|---|---|---|---|---|---|
| <b>IGNITION</b>  |             |           |   |   |   |   |   |   |  |  |   |   |   |   |   |   |
|  |             |           |   |   |   |   |   |   |  |  |   |   |   |   |   |   |
| <b>TRUCK MAKE/MODEL</b>  | <b>FROM</b> | <b>TO</b> | <b>SILCA REF.</b>   | <b>TRANSP. TYPE</b>   | <b>ID</b>   | <b>COPY</b>   | <b>ID</b>   | <b>COPY</b>   | <b>ID</b>  | <b>COPY</b>  | <b>STP</b>  |   |   |   |   |   |
|    | 1995        | 2010      | <br>Ref. |  | <br>FAST COPY PLUS<br>RW4 PLUS | <br>FAST COPY PLUS<br>RW4 PLUS | <br>FAST COPY<br>RW4 | <br>FAST COPY<br>RW4 | <br>RW3 | <br>RW3 |  |  |  |  |  |  |
| <b>IVECO</b>   |             |           |   |   |   |   |   |   |  |  |   |   |   |   |   |   |
| EUROCARGO  | 2002        | 2007      | SIP22EHP  | PH / CR2  | 46  | Y   | 46  | P-BOX   | 46   |  |   |   | ←   |   |   |   |
| EUROCARGO  | 2008        |           | SIP22EH2  | TEX / CR  | 62  | Y   | 62  | Y   | 62   | PC   |   |   | ←   |   |   |   |
| EUROSTAR   | 1998        | 2002      |   | PH / CR2  | 46  |   | 46  |   | 46   |  |   |   | ←   |   |   |   |
| EUROSTAR   | 1998        | 2002      | GT10EHP   | PH / CR2  | 46  | Y   | 46  | P-BOX   | 46   |  |   |   | ←   |   |   |   |
| STRALIS  | 2002        | 2007      | SIP22EHP  | PH / CR2  | 46  | Y   | 46  | P-BOX   | 46   |  |   |   | ←   |   |   |   |
| STRALIS  | 2008        |           | SIP22EH2  | TEX / CR  | 62  | Y   | 62  | Y   | 62   | PC   |   |   | ←   |   |   |   |

FOR:  
PER:

## CISA (I)

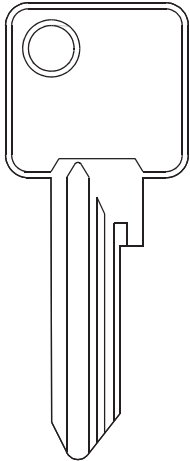

SP - TSP

ABUS (D)



UNOCODE 399 EVO

OPTIONAL



### D735434ZB

Clamp V103  
Morsetto V103  
Spannbacken V103  
Etau V103  
Mordaza V103  
Mordente V103

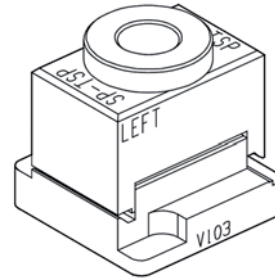

*System protected by a password issued by Silca on receipt of authorization.  
Sistema protetto da Password rilasciata da Silca a fronte di autorizzazione.  
System geschützt durch von Silca geliefertes Password auf Genehmigung.  
Système protégé par un Password qui est émis par Silca sur demande d'émission.  
Sistema protegido por Password que expide Silca contra autorización.*

FOR:  
PER:

## LINCE (E)

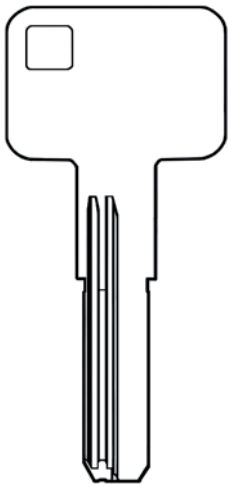

C5X

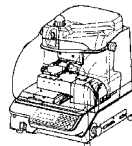

TRIAX-E.CODE

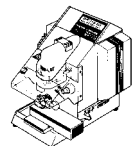

QUATTROCODE

OPTIONAL



### D737126ZB

Clamp R127  
Morsetto R127  
Spannbacken R127  
Etau R127  
Mordaza R127  
Mordente R127

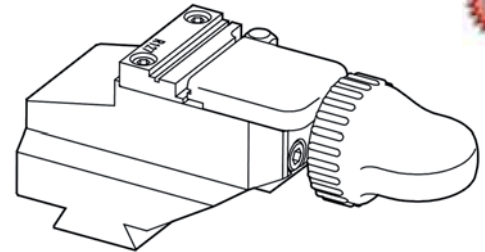

Starting from Triax Software version 5.1.073 DB 25.00  
Dalla versione Software Triax 5.1.073 DB 25.00  
Ab Triax Software Version 5.1.073 DB 25.00  
À partir du software Triax version 5.1.073 DB 25.00  
Desde software Triax versión 5.1.073 DB 25.00  
A partir da versão software Triax 5.1.073 DB 25.00

OPTIONAL

| C5X Interp. |  | C5X |  |
|-------------|--|-----|--|
| 301         | <b>D737183ZB</b><br>Cutter W301 (carbide)<br>Fresa W301 (metallo duro)<br>Fräser W301 (Hartmetall)<br>Fraise W301 (au carbure)<br>Fresa W301 (metal duro)<br>Fresa W301 (metal duro) | 116 | <b>D709792ZB</b><br>Cutter W116 (carbide)<br>Fresa W116 (metallo duro)<br>Fräser W116 (Hartmetall)<br>Fraise W116 (au carbure)<br>Fresa W116 (metal duro)<br>Fresa W116 (metal duro) |

*System protected by a password issued by Silca on receipt of authorization.  
Sistema protetto da password rilasciata da Silca a fronte di autorizzazione.  
System geschützt durch von Silca geliefertes Password auf Genehmigung.  
Système protégé par un password qui est émis par Silca sur autorisation.  
Sistema protegido por password que expide Silca contra autorización.*



## SOFTWARE NEWS



### SILCA KEY PROGRAMS

Update 2/2010



#### SILCA TRANSPONDER PROGRAM NEW FEATURES

STP



## 46 new vehicle models



Update with 46 new vehicle models.

Aggiornamento con 46 nuovi modelli auto.

Aktualisierung mit 46 neuen Automodellen.

Mise à jour avec 46 nouveaux modèles auto.

Actualización con 46 modelos vehículo nuevos.

Atualização com 46 novos modelos de automóvel.



## Silca Transponder Program



Addition of 3 new SILCA keys for copying ID46 transponders.

Aggiunta di 3 nuove chiavi SILCA per la copia del transponder ID46.

Hinzufügen von 3 neuen SILCA Schlüsseln zum Kopieren des Transponders ID46.

Rajout de 3 nouvelles clés SILCA pour la copie du transpondeur ID46.

Se han añadido 3 llaves SILCA nuevas para copiar el transponder ID46.

Acréscimo de 3 novas chaves SILCA para a cópia do transponder ID46.

*Silca recommends to read carefully the on-line documentation to learn the procedure for copying ID46 transponders. / Si consiglia di leggere sempre la documentazione in linea per apprendere la procedura corretta da seguire per la copia transponder ID46. / Lesen der Unterlagen on line, um Anleitungen zum Kopieren des Transponders ID46 zu erhalten. / Lire la documentation en ligne pour apprendre la bonne marche à suivre pour copier le transpondeur ID46. / Leer la documentación en línea para aprender el procedimiento correcto que hay que seguir para copiar el transponder ID46. / Leia a documentação on-line para aprender o procedimento correcto a realizar para a cópia de transponder ID46.*

## SOFTWARE NEWS



### SILCA KEY PROGRAMS

### Future developments (2011)

NEW

SILCA KEY PROGRAMS FUTURE DEVELOPMENTS (JANUARY 2011)

SKP

JAN.  
2011



#### **Future developments for SILCA KEY PROGRAMS (January 2011)**

From January 2011 you will also be able to update the SILCA KEY PROGRAMS program on the WEB.

This will generate some changes:

- The electronic support will be DVD only (**no longer CD-ROM**);
- The Windows® Operating Systems possible will be: Windows® 2000, Windows® XP, Windows VISTA™ and Windows® 7;
- Updates for Operating Systems Windows® 95, Windows® ME, Windows® 98 and Windows® NT will no longer be available.

#### **Sviluppi futuri per il SILCA KEY PROGRAMS (Da Gennaio 2011)**

Da Gennaio 2011, il programma SILCA KEY PROGRAMS sarà aggiornabile anche tramite il WEB.

Per questo motivo vi saranno alcune novità:

- Il supporto elettronico sarà solo DVD (**non più CD-ROM**);
- I Sistemi Operativi Windows® supportati saranno: Windows® 2000, Windows® XP, Windows VISTA™ e Windows® 7;
- Non saranno più disponibili aggiornamenti per sistemi operativi quali Windows® 95, Windows® ME, Windows® 98 e Windows® NT.

#### **Zukünftige Entwicklungen für das SILCA KEY PROGRAMS (ab Januar 2011)**

Ab Januar 2011 ist das Programm SILCA KEY PROGRAMS auch über das WEB aktualisierbar.

Daher gibt es einige Neuheiten:

- Es werden nur mehr DVD verwendet (**nicht mehr CD-ROM**);
- Die Betriebssysteme Windows® sind: Windows® 2000, Windows® XP, Windows VISTA™ und Windows® 7;
- Es gibt keine Aktualisierungen mehr für Betriebssysteme wie Windows® 95, Windows® ME, Windows® 98 und Windows® NT.



## SOFTWARE NEWS



### SILCA KEY PROGRAMS

### Future developments (2011)

NEW

SILCA KEY PROGRAMS FUTURE DEVELOPMENTS (JANUARY 2011)

SKP

JAN.  
2011



#### **Développements futurs pour SILCA KEY PROGRAMS (A partir de janvier 2011)**

Dès Janvier 2011, le logiciel SILCA KEY PROGRAMS pourra être mis à jour sur le Net aussi.

C'est pour cette raison qu'il y aura certaines nouveautés:

- Il n'y aura que le DVD comme support électronique (**plus de CD-ROM**);
- Les systèmes d'exploitation Windows® secondés seront les suivants: Windows® 2000, Windows® XP, Windows VISTA™ et Windows® 7 ;
- Aucune mise à jour pour les systèmes d'exploitation tels que Windows® 95, Windows® ME, Windows® 98 et Windows® NT ne sera disponible.

#### **Desarrollos futuros para el SILCA KEY PROGRAMS (A partir de Enero de 2011)**

A partir de Enero de 2011, el programa SILCA KEY PROGRAMS podrá actualizarse incluso por medio de la WEB.

Por este motivo habrá algunas novedades:

- El soporte electrónico será sólo DVD (**ya no CD-ROM**);
- Los Sistemas Operativos Windows® soportados serán: Windows® 2000, Windows® XP, Windows VISTA™ y Windows® 7;
- Ya no estarán disponibles actualizaciones para sistemas operativos como Windows® 95, Windows® ME, Windows® 98 y Windows® NT.

#### **Desenvolvimentos futuros para o SILCA KEY PROGRAMS (De Janeiro de 2011)**

A partir de Janeiro de 2011, o programa SILCA KEY PROGRAMS também poderá ser actualizado através da WEB.

Por esta razão, as novidades serão as seguintes:

- O suporte electrónico será apenas DVD (**já não CD-ROM**) ;
- Os Sistemas Operativos Windows® suportados serão: Windows® 2000, Windows® XP, Windows VISTA™ e Windows® 7 ;
- Já não estarão disponíveis actualizações para sistemas operativos como Windows® 95, Windows® ME, Windows® 98 e Windows® NT.



## NEW SILCA CATALOGUES



**NEW, COMPLETE, DON'T MISS THEM!**  
**NUOVI, COMPLETI E IMPERDIBILI!**  
**NEUE, KOMPLETTE, UNERSETZLICHE!**

**NOUVEAUX, COMPLETS, A NE PAS RATER!**  
**¡NUEVOS, COMPLETOS, IMPERDIBLES!**  
**NOVOS, COMPLETOS E IMPERDÍVEIS!**

Updated Silca key range: the largest range in the world to choose from.

- Clear and synthetic format.
- The best of information continually updated by Silca.

Gamme de clés Silca à jour: faites votre choix dans le plus grand assortiment du monde.

- Mise en page claire et synthétique.
- Le meilleur de l'info sans cesse actualisé par Silca.

Gamma chiavi Silca aggiornata: la gamma più ampia al mondo all'interno della quale poter scegliere.

- Impaginato chiaro e sintetico.
- Il meglio dell'informazione continuamente aggiornata da Silca.

Gama de llaves Silca actualizada: la gama más amplia en el mundo en la que Ud. puede elegir.

- Forma clara y sintética.
- Lo mejor de la información continuamente actualizada por Silca.

Aktualisiert Silca Produktpalette: die reichhaltigste Produktpalette auf der Welt, aus der Sie wählen können.

- Übersichtlichen und synthetischen Form.
- Die besten, laufend von Silca aktualisierten Informationen.

Gama de chaves Silca actualizada: a mais ampla gama no mundo, para que possa escolher a solução ideal para si.

- Paginação clara e sintética.
- O melhor da informação continuamente actualizada pela Silca.

**THE CAR BOOK 3**

To order a copy of this catalogue: code P394.  
 Per ordinare una copia di questo catalogo: codice P394.  
 Um eine Kopie von diesem Katalog zu bestellen: Code P394.  
 Pour commander une copie de ce catalogue: code P394.  
 Para ordenar una copia de este catálogo: código P394.  
 Para ordenar uma cópia deste catálogo: código P394.

**207**

To order a copy of this catalogue: code P393.  
 Per ordinare una copia di questo catalogo: codice P393.  
 Um eine Kopie von diesem Katalog zu bestellen: Code P393.  
 Pour commander une copie de ce catalogue: code P393.  
 Para ordenar una copia de este catálogo: código P393.  
 Para ordenar uma cópia deste catálogo: código P393.

**107**

To order a copy of this catalogue: code P603.  
 Per ordinare una copia di questo catalogo: codice P603.  
 Um eine Kopie von diesem Katalog zu bestellen: Code P603.  
 Pour commander une copie de ce catalogue: code P603.  
 Para ordenar una copia de este catálogo: código P603.  
 Para ordenar uma cópia deste catálogo: código P603.